

STAMSHAW JUNIOR SCHOOL

Health, Safety and Welfare Policy

2024-25



Revised by School	January 2025
Responsible Person	Rob Jones (HT)
Responsible Committee	LGB
Next Review	January 2026

Proud to be part of the UNIVERSITY OF CHICHESTER ACADEMY TRUST

CONTENTS

- 1 The Trust Health & Safety Policy**
- 2 Policy Statement**
- 3 Organisation**
 - a. Employer responsibility**
 - b. Responsible Manager**
 - c. All staff (including volunteers)**
 - d. Site manager**
 - e. The LGB**
 - f. Health and Safety Officer**
 - g. All Teachers, Cover Supervisors and support staff**
 - h. Finance & Resource Committee (LGB)**
 - i. Fire Safety Co-ordinator**
 - j. Legionella Competent Person**
 - k. Asbestos Competent Person**
 - l. Accident Investigator**
 - m. Educational Visits Co-ordinator**
 - n. PEEP Manager**
 - m. Health and Safety Advisor**
- 4 Arrangements**
 - a. Health and Safety assistance and advice**
 - b. Accident/Incident reporting and investigation**
 - c. Administration of medicines**
 - d. Asbestos management**
 - e. Child protection**
 - f. Community Users**
 - g. Contractors on site**
 - h. Curriculum activities**
 - i. Defect reporting book**
 - j. Display screen equipment**
 - k. Electrical equipment**
 - l. Emergency procedures**
 - m. Fire Safety**
 - n. First Aid**
 - o. Gas**
 - p. General Equipment**
 - q. Good Housekeeping**
 - r. Hazardous Substances**
 - s. Health and Safety Diary**
 - t. Hot drinks**
 - u. Inspections and monitoring**

- v. Kitchen
- w. Legionella management
- x. Lone Working
- y. Mobile phones
- z. Moving and Handling
- aa. Off-Site Activities
- bb. Physical Intervention
- cc. Provision of Information
- dd. Risk Assessment
- ee. Security
- ff. Smoking
- gg. Stress and Wellbeing
- hh. Traffic Management
- ii. Training
- jj. Violent Incidents
- kk. Visitors
- ll. Welfare Facilities
- mm. Work Equipment
- nn. Work at Height

ANNEXES

- a. List of roles and responsibilities.
- b. Investigation form
- c. Near miss form
- d. Lockdown procedures
- e. Fire Evacuation Policy
- f. Premises safety checklist
- g. Risk Register
- h. Risk Assessment template
- i. List of school key holders
- j. H& S Induction checklist
- k. Medicine Consent Form
- l. Water Schematic Drawing.
- m. Violent Incident Report Form
- n. Daily, weekly, monthly and 3 monthly checks

This policy will be reviewed annually.

Forward

“This statement of the University of Chichester Academy Trust’s Health and Safety Policy towards the conduct of its activities, reaffirms the intent of the Trust and its Board to conduct its affairs with all due regard for the health and safety of staff, pupils, parents and visitors. It is concerned with the protection of everyone who is lawfully on Trust property who may be affected by its activities and seeks through clearly defined responsibilities to achieve the highest standard of health and safety that is reasonably practicable. This Health and Safety Policy imposes a duty on all of us to take care of our own health and safety and those who may be affected by our activities. I ask every one of you to think constantly about how you can improve the health and safety impacts of your work as well as that of your colleagues and pupils. Please give the Policy your total and active support.”

Jennese Alozie CEO

University of Chichester Academy Trust Health and Safety Statement

The Trust’s Board recognises its responsibilities under the relevant Health, Safety and Environmental legislation, in particular the Health and Safety at Work etc. Act 1974, The Management of Health and Safety at Work Regulations 1999 and all other relevant statutory regulations. The Trust is committed both as an employer and as a provider of education to the provision of a safe and healthy working environment for members of staff, pupils, parents and visitors. In furtherance of this Policy, the Board through its Local Governing Bodies will, so far as is reasonably practicable, provide:

- Processes to identify hazards and assess risks through recognised risk control systems.
- Clear policies, guidance and procedures to support the Health and Safety Policy.
- Safe premises, plant, equipment and systems of work.
- Adequate facilities, protective equipment and clothing to enable articles and substances to be used, transported, handled and stored safely.
- Such information, instruction and supervision as are necessary to ensure the health and safety of staff and pupils and visitors.
- Appropriate arrangements for consultation with staff and union representatives on measures for achieving agreed health and safety performance.

The Board considers issues of health and safety to be of the highest importance and priority and seeks to maintain commitment to continuous improvement and awareness. The Board also undertakes, through its Local Governing Bodies, to ensure that staff and pupils are consulted and involved in all areas of health and safety.

While recognising its own legal responsibilities in the matter of health and safety at work, the Board requires all staff, pupils, parents and visitors to act safely and to co-operate in meeting these obligations. The Board believes that health and safety at work is the responsibility of all. It will encourage employees to take an active role in ensuring that a safe working environment is maintained.

This policy will be reviewed as appropriate by the Trust, taking into account any new legislation or practices that may affect this document.

1. Introduction: The Legal Position

The concept that employees should be safe at work is not a recent phenomenon. Legislation was developed in the 1970s to streamline the many different statutes governing safety issues making management responsible for the provision and maintenance of adequate standards and policies. Although there are many different statutes governing safety issues, health and safety is not only governed by legislation. Under what is known as ‘common law’ all employers have a duty of care imposed on them to protect their employees. There is also a term implied into all employment contracts requiring employees to comply with the Trust’s health and safety policies and guidelines.

The Legislation relating to health and safety is extensive. One of the most statutes is the Health and Safety

at Work etc. Act 1974 (HSWA). All work places are covered by this legislation which states that an employee must do everything reasonably practicable to provide a safe and healthy workplace with adequate welfare facilities. HASAWA has been supported by various sets of regulations, codes of practice and guidance, all of which deal with various aspects of health and safety.

The organisation and management of health and safety is a corporate responsibility and failure to comply with health and safety requirements can have serious consequences – for the Trust, the Board, Governing Bodies and individuals. Health and safety law states that organisations must provide a written health and safety policy, assess risks to staff, pupils, partners, stakeholders and any other people who could be affected by the activities of the Trust, arrange for the effective planning, organisation, control, monitoring and review of preventive and protective measures ensure that staff and pupils have access to competent health and safety advice, and consult staff about their risks at work and current preventive and protective measures. Responsibility for Health and Safety is delegated to academies in the Scheme of Delegation.

2. Health and safety at work: risks and benefits

Addressing health and safety should not be seen as a regulatory burden: it offers significant opportunities. Benefits include:

- Reduced costs and reduced risks – accidents are fewer, the threat of legal action is lessened, employee absence and turnover rates are lower.
- Improved standing among collaborative partners and suppliers.
- A better reputation for corporate responsibility among pupils and members of the community.
- Increased productivity – employees and pupils are healthier, happier and better motivated.

3. Essential principles

It is the policy of the Trust to comply with the legal obligations outlined in HASAWA, the Management of Health and Safety at Work Regulations 1999 and any other relevant statutory provisions by delegating to school Governing Bodies the responsibility for ensuring:

- The provision of a safe and healthy working environment with adequate facilities and arrangements for welfare.
- Physical equipment and structures are maintained to be intrinsically safe and without risks – including the means for accessing the workplace and exiting from it.
- Information, instruction, supervision and training are provided to ensure safety by competent personnel. Prescribed information will also be supplied to non-employees e.g. visitors and contractors, about any work that might affect their health and safety.
- Procedures are drawn up and reviewed for the safe use of equipment, safe systems of work, and the safe use, handling and storage of materials.
- Training is provided and reviewed for employees and for those appointed as health and safety co-ordinators/fire wardens/risk assessors/first aiders.
- The provision and use of protective clothing and equipment where necessary.
- That medical advice is available where needed.

Arrangements are put in place for the periodic inspection of work places and methods of working and the monitoring of any corrective action necessary.

Arrangements are in place to ensure that consultation is facilitated between management and employee representatives.

- Sufficient time and other resources are given to employees with health and safety duties to allow them to discharge these duties effectively.

The Trust's Health and Safety Policy will evolve over time, e.g. in the light of major organisational changes

such as restructuring or a significant acquisition.

4. Leading Health and Safety

The Trust expects all Local Governing Bodies to ensure that health and safety is integrated with other core management functions and that all employees and pupils are equipped with the necessary information, instruction, training and supervision to carry out their responsibilities. This includes:

- 1) Strong and active leadership from the top:
- 2) Employee involvement:
- 3) Assessment and review:

The Board expects all Governing Bodies to do this by purchasing third party expert support for H&S, either by taking out a local authority SLA or by engaging another professional to offer a similar service; this must include an annual audit.

5. Nominated Health and Safety Personnel

Employees occupying a variety of management, teaching and professional support posts are nominated as volunteers to monitor health and safety across the Trust. Nominated personnel include:

Rob Jones - Headteacher

Sam Cantini - Deputy Headteacher

Mike Bond – Site Manager

5.1 Health and Safety Co-ordinators

The Health and Safety Co-ordinators undertake a vital role in ensuring safe and compliant working practices in their area. They act as a liaison between their department and the academy's advisers on health and safety matters and are required to attend training to help them in their role. The co-ordinator's:

- Undertake training to carry out regular workplace inspections and to report health and safety concerns and deficiencies, ensuring that any recommendations or remedial actions are acted upon within an appropriate time frame.
- Maintain a health and safety file and complete any necessary returns to the health and safety office using appropriate pro-forma.
- Disseminate health and safety information to staff and pupils, as appropriate.

5.2 Fire Marshals

Nominated Fire Marshals are responsible for monitoring the effectiveness of fire safety measures throughout the Trust. Fire Marshals are provided with training on fire awareness and the use of fire extinguishers. Fire Marshals:

- Report shortfalls within their work[places on fire safety issues to the Health and Safety Co-ordinator
- Assist with the swift and calm evacuation of persons from their area on hearing a fire.
- Report to the person responsible for co-ordinating a fire rescue and provide information where required.

5.3 Risk Assessors

All staff who organise or control activities such as field trips, equipment or facilities, will receive training in risk assessment. The Risk Assessors co-ordinate risk assessments in their area, returning completed and accurate paperwork to the health and safety team. A Risk Assessor will be trained in identifying and controlling risks.

5.4 First Aiders

First Aiders support the health and safety of staff and pupils across the Trust. First Aiders must attend regular First Aid training. First Aiders attend to incidents and keep records of all first aid treatments they have administered including details on accident/incident report forms.

5.5 Health and Safety Officer

The academy's Health and Safety Officer provides advice and guidance on all matters relating to health and safety for staff, pupils and nominated health and safety personnel. The Health and Safety Officer takes the

lead responsibility for reviewing and monitoring the effectiveness of health and safety policies.

The Health and Safety Officer has the responsibility for devising and implementing a health and safety audit programme as well as developing health and safety policies and guidance and the provision of training. As well as reporting health and safety concerns and outcomes to the Health and Safety Committee, the Health and Safety Officer audits health and safety performance and liaises with enforcement authorities and local authorities on matters affecting Trust premises or staff. The Health and Safety Officer also takes responsibility for investigating and reporting any accidents or near-misses to the Health and Safety Executive. The Health and Safety Officer co-ordinates and chairs Health and Safety meetings involving Health and Safety Co-ordinators and Fire Wardens.

5.6 Finance and Resources Committee

The Chair of Finance and Resources ensures Health and Safety is an item on the agenda so that they take responsibility for the monitoring of policies and procedures and safety working practises within the academy. A member of this committee regularly meets with the school's site manager to conduct a Health and Safety walk across the site identifying actions as required.

6. Health and Safety responsibilities

6.1 Governing Bodies

Health and safety is a corporate governance issue. The Trust recognises that it can only achieve the highest standards of health and safety management with the active involvement of its Governing Bodies. The LGB will integrate health and safety into the main governance structures, including sub-committees, such as risk management and audit. All members of the LGB will take the lead in ensuring the communication of health and safety duties and benefits throughout the organisation. The LGB will 'own' and understand the key issues involved and decide how best to communicate, promote and champion health and safety.

The LGB will:

- Ensure that health and safety appears regularly on the agenda for LGB meetings.
- Ensure that health and safety arrangements are adequately resourced.
- Encourage staff or their representatives to be involved in decisions that affect their health and safety.
- Ensure that LGB decisions are made in the context of the health and safety policy.
- Consider health and safety when deciding senior management appointments.
- Support staff involvement in health and safety.
- Request periodic audits of the effectiveness of management structures and risk controls for health and safety.

6.2 Employees

Every employee has health and safety responsibilities from statute and civil law as well as under their contract of employment. It is the duty of all employees to co-operate in implementing health and safety policy by:

- Acting with due care for the health, safety and welfare of themselves and others and co-operating with managers by complying with instructions and procedures for safe working.
- Not intentionally or recklessly interfering with or misusing anything provided in the interests of health and safety or welfare.
- Evacuating pupils promptly from teaching rooms in the case of emergency situations and fire drills, in accordance with Trust procedures.
- Making proper use of protective clothing and safety equipment provided (in accordance with any training or instruction provided by the Trust), reporting any loss or obvious defect in that equipment and taking reasonable care of it.
- Informing their manager(s) of any defects in equipment, structures or safety procedures, however trivial it might seem, which they are aware of and incidents which have led or might have led to injury or damage.

- Co-operating with any investigation that might be undertaken with the object of investigating incidents or preventing accidents in the future.
- Making sure that an appropriate and accurate record is made on the LGB's accident/incident report form, following an accident or near-miss which has (or could have) led to injury or ill-health and reported to the Health and Safety Officer.
- Taking responsibility for the safety of pupils and visitors, ensuring that any proposed new activity is risk assessed before the activity commences.
- Ensuring risk assessments are conducted where appropriate (e.g. for field trips, work in laboratories or workshops) and all those who may be affected are advised of relevant findings and risk reduction strategies.

7. Assessment and review: Monitoring and Reporting

Monitoring and reporting are vital parts of the health and safety culture as well as effective management systems and practices which ensure that health and safety risks are dealt with sensibly, responsibly and proportionately. Formally reviewing policies, procedures and practices will help to ensure that established principles are embedded in the organisational culture and adhered to.

A formal review of health and safety performance is essential. It allows governing bodies to establish principles – strong and active leadership, staff involvement, and assessment – have been embedded in the organisation and whether the system is effective in managing risk and protecting people.

An annual audit is carried out by the Trust's Health and Safety Officer to ensure that the Trust is complying with relevant health and safety legislation. A premises fire safety risk assessment is to be carried out each year by the school. Premises improvements are prioritised and implemented by the LGB.

The school must keep records and incidents reports that they have made during the year by keeping a copy of the report form. Accident and incident reports must be kept for a period of three years (the Health and Safety Officer will keep records for longer than this). In addition, records must be kept of the steps taken after an incident has occurred, including details where applicable on accident investigations, risk assessment, subsequent decisions on amendments to procedure and, where necessary related communications.

8. Health and Safety Guidance

The management of health and safety is supported through a variety of policies and procedures and health and safety guidance on topics such as fire evacuation, manual handling, noise at work, personal protective equipment, portable appliance testing, risk assessment, and other health and well-being policies. Policies will be developed as a result of changing legislation e.g. Corporate Manslaughter and Driving at Work.

9. Managing Health and Wellbeing

The Trust is committed to supporting the health and wellbeing of its employees by encouraging the adoption of healthier lifestyles. The philosophy which underpins this commitment is one of self-help and individual responsibility, promoting and supporting good practise to ensure staff feel supported in their work,

10. Absence Monitoring

The continuing use of sickness absence procedures. Occupational Health involvement, return-to-work interviews and the support of a confidential counselling service are identified as the most effective approaches for managing absence and ill-health. The central HR team at the Trust can advise further on.

11. Further Information and support.

A broad range of health and safety information is available on the Health and Safety Executive website at www.hse.gov.uk

STATEMENT OF INTENT:

The Local Governing Body (LGB) of Stamshaw Junior School believes that ensuring the health and safety of staff, pupils and visitors is essential to the success of the school. Health and Safety is a corporate governance issue.

We are committed to:

- providing a safe and healthy working and learning environment
- reducing the possibilities of accidents and work related ill health
- assessing and controlling risks from curriculum and non-curriculum work activities
- complying with statutory requirements as a minimum
- ensuring health and safety appears regularly on the agenda for LGB meetings and have a governor with a specific health and safety remit who meets regularly with the site manger to discuss and monitor Health and safety across school
- requesting periodic audits of the effectiveness of management structures and risk controls for health and safety.
- ensuring safe working methods and providing safe equipment
- providing effective information, instruction and training
- monitoring and reviewing systems to make sure they are effective
- developing and maintaining a positive health and safety culture through communication and consultation with employees and their representatives on health and safety matters
- setting targets and objectives to develop a culture of continuous improvement
- ensuring adequate welfare facilities exist at the school
- ensuring adequate resources are made available for health and safety issues, so far as is reasonably practicable

A health and safety management system has been created to ensure the above commitments can be met. All governors, staff and pupils will play their part in its implementation. To comply with the Local Governing Body's Statement of Intent the school's normal management structure have additional responsibilities, as detailed below.

Name Sherri Bailey

Signature
(Chair of LGB)

Date:

(Chair of LGB to sign, then to be displayed next to H&S poster)

STATEMENT OF INTENT:

The Interim Executive Board (IEB) of Stamshaw Junior School believes that ensuring the health and safety of staff, pupils and visitors is essential to the success of the school. Health and Safety is a corporate governance issue.

We are committed to:

- providing a safe and healthy working and learning environment
- reducing the possibilities of accidents and work related ill health
- assessing and controlling risks from curriculum and non-curriculum work activities
- complying with statutory requirements as a minimum
- ensuring health and safety appears regularly on the agenda for IEB meetings and have a governor with a specific health and safety remit who meets regularly with the site manger to discuss and monitor Health and safety across school
- requesting periodic audits of the effectiveness of management structures and risk controls for health and safety.
- ensuring safe working methods and providing safe equipment
- providing effective information, instruction and training
- monitoring and reviewing systems to make sure they are effective
- developing and maintaining a positive health and safety culture through communication and consultation with employees and their representatives on health and safety matters
- setting targets and objectives to develop a culture of continuous improvement
- ensuring adequate welfare facilities exist at the school
- ensuring adequate resources are made available for health and safety issues, so far as is reasonably practicable

A health and safety management system has been created to ensure the above commitments can be met. All governors, staff and pupils will play their part in its implementation. To comply with the Interim Executive Body's Statement of Intent the school's normal management structure have additional responsibilities, as detailed below.

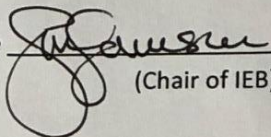
Name S. SAMSON Signature  Date: 26/11/19 .

(Chair of IEB)

(Chair of IEB to sign, then to be displayed next to H&S poster)

Specific Site: Stamshaw Junior School

It is our policy to carry out our activities in such a way as to ensure so far as is reasonably practicable, the health, safety and welfare of all our employees and all persons likely to be affected by our activities including the general public where appropriate.

We will co-operate and co-ordinate with employees, contractors, sub-contractors, University of Chichester Academy Trust departments, Licensees & Lettings and the occupiers and owners of premises and land where we are commissioned to work in order to pursue our Health and Safety Policy aims. We follow the Trust guidance in their policy as well as the site specific document that follows.

Our aims are to:

- Provide and maintain a safe and healthy working environment ensuring the welfare of all persons.
- Maintain control of health and safety risks arising from our activities.
- Comply with statutory requirements as a minimum standard of safety.
- Consult with all staff on matters affecting their health, safety and welfare.
- Provide and maintain safe systems, equipment and machinery.
- Ensure safe handling, storage and use of substances.
- Provide appropriate information, instruction and supervision for everyone
- Ensure that staff are suitably trained and competent to do their work safely.
- Continually develop a safety culture.
- Assess risks, record significant findings and monitor safety arrangements.
- Review and revise safety policies and procedures periodically and when circumstances may introduce a requirement to amend or improve arrangements.
- Develop and maintain a positive health and safety culture through regular communication and consultation with employees and their representatives on health and safety matters, to remove or reduce the possibility of accidents and injuries or ill health.
- Develop our health and safety management system

To ensure that the above commitments can be met. All staff and governors will be instrumental in its implementation.

Health and Safety Assistance & Advice is used from a variety of recommended bodies, however for Stamshaw Junior School, **Portsmouth City Council** is the competent source of safety guidance for the school as required under Reg.7 or the Management of Health and Safety at Work Regulations 1999. Where issues arise or concerns arise then advice from **Portsmouth City Council** shall be sought

Organisation

a. Employer Responsibility

The overall responsibility for health and safety at Stamshaw Junior School is held by the LGB of Stamshaw Junior School, Portsmouth as part of the University of Chichester Academy Trust who will:

- Ensure that health and safety has a high profile.
- Ensure adequate resources for health and safety are made available.
- Consult and advise staff regarding health and safety requirements and arrangements.
- Periodically monitor and review local health and safety arrangements.

b. Responsible Manager

The responsible manager for the school is the Headteacher of the School (Mr Rob Jones) who will act to:

- Develop a safety culture throughout the school, fully committing to the LGB Statement of Intent for Health, Safety & Welfare
- Write a clear local policy for Health & Safety, communicating it to all staff and others requiring the information
- Consult staff and provide information, training and instruction so that staff are able to perform their various tasks safely and effectively.
- Assess and control risk on the premises as part of everyday Management.
- Ensure a safe and healthy environment and provide suitable welfare facilities.
- Make operational decisions regarding health and safety.
- Ensure a safe periodical safety tours and inspections are carried out.
- Ensure significant hazards are assessed and risks are managed to prevent harm.
- Ensure risk assessments of the premises and working practices are undertaken.
- Ensure staff are aware of their health and safety responsibilities.
- Periodically update governing bodies/partnerships as appropriate.
- Ensure that local safety policies and procedures are produced, monitored and periodically reviewed. A list of health and safety related policies and plans is at Annex A.

c. All Staff (including volunteers}

Every employee has health and safety responsibilities from statute and civil law as well as under their contract of employment.

All staff have a **STATUTORY OBLIGATION** to co-operate with the requirements of this policy and take care of their own health and safety and that of others affected by their activities by:

- Acting with due care for the health, safety and welfare of themselves and others
- Following and supporting the school health and safety arrangements.
- Ensuring their own work area remains safe at all times.
- Not interfering with health and safety arrangements or misusing equipment.
- Complying with all safety procedures, whether written or verbally advised, for their own protection and the protection of those who may be affected by their actions. (e.g. evacuation, risk management, first aid, protective clothing etc.)
- Evacuating pupils in their care promptly from the teaching rooms and other spaces around the school in case of emergency situations and fire drills, in accordance with school and Trust procedures
- Ensuring risk assessments are conducted and carried out as appropriate
- Reporting safety concerns to their staff representative or other appropriate person.
- Reporting and making an accurate record of any incident that has led, or could have led to damage or injury to the Health & Safety Officer
- Assisting in investigations due to accidents, dangerous occurrences or near misses.
- Not acting or omitting to act in any way that may cause harm or ill-health to others.

d. The Site Manager

The site manager (in addition to all staff responsibilities) is **responsible for undertaking a wide range of typical health and safety related duties** on behalf of, and under the direction of the Headteacher. These will include:

- Legionella temperature and flushing checks; alongside the SLA for other checks
- Showerhead descaling (N/A)
- Ladder, stepladder and step stool inspections
- Fire door checks – monthly
- Emergency lighting tests – monthly
- Fire alarm tests weekly

- Supporting asbestos management
- Carrying out minor repairs
- Supporting and monitoring external contractors in their duties

The site manager is to attend a legionella training course every three years. He is to attend other safety related courses as appropriate. He is to work within the parameters of any provided training and in accordance with risk assessments and the on-site safe working practice. He is to work within his level of competence and seek appropriate guidance and direction from the Health and Safety Officer.

e. The LGB

The Local will:

- Ensure that health and safety appear regularly on the agenda for LGB meetings and identify a named Governor with responsibility for Health & Safety.
- Make arrangements for an independent member of the LGB to act as a health and safety champion.
- Ensure that health and safety arrangements are adequately resourced.
- Encourage staff or their representatives to be involved in decisions that affect their health and safety.
- Ensure that LGB decisions are made in the context of the health and safety policy.
- Consider health and safety when deciding senior management appointments.
- Support staff involvement in health and safety.
- Request periodic audits of the effectiveness of management structures and risk controls for health and safety.

f. Health and Safety Officer (The site manager in partnership with Sam Cantini)

In addition to all staff responsibilities, the Health and Safety Officer will manage, advise and co-ordinate local safety matters on behalf of, and under the direction of the Headteacher in particular, he/she will:

- Maintain all health and safety records
- Manage the health and safety training requirements
- Manage the updating of risk assessments and health and safety policies
- Carry out risk assessments
- Carry out the induction training for all staff, student teachers and parent volunteers
- Co-ordinate the annual general workplace monitoring inspections and performance monitoring process.
- Make provision for the inspection and maintenance of work equipment throughout the school.
- Advise the Headteacher of situations or activities which are potentially hazardous to the health and safety of staff, pupils and visitors.
- Ensure that staff are adequately instructed in safety and welfare matters about their specific work place and the school generally.
- Carry out any other functions required by the Headteacher or LGB.

The Health and Safety Officer is to attend health and safety courses and to work within their level of competence and seek appropriate guidance and direction from the Headteacher and the Health and Safety Advisor as required.

g. All Teachers, Cover Supervisors and support staff

In addition to all staff responsibilities, the responsibility of applying local safety procedures on a day-to-day basis rests with the teachers and TAs. Where any new procedures or operation is introduced in the area of their responsibility, they are to liaise appropriately so that the associated risks are assessed, and any precautions deemed necessary are implemented. They are to ensure that all new members of staff under their control are instructed in their own individual responsibilities with regards to health and safety, and they will appropriately monitor those new staff. They are to make periodic inspections of their areas of responsibility, taking prompt remedial action where necessary to control risk.

h. Finance and Resources Committee (Currently within the LGB and all responsibilities assumed by them)

The purpose of the Finance and Resources Committee is to report health and safety considerations to the LGB. The Finance and Resource committee consists of a minimum of three governors and Headteacher and they shall meet each term. During the year they shall audit two health and safety policies and carry out an annual premises survey.

i. Pupils:

Pupils, allowing for their age and aptitude, are expected to:

- exercise personal responsibility for the health and safety of themselves and others.
- observe standards of dress consistent with safety and/or hygiene.
- observe all the health and safety rules of the school and in particular the instructions of staff given in an emergency.
- use and not wilfully misuse, neglect or interfere with things provided for their health and safety.

j. Health and Safety Representatives:

Safety Representatives can either be appointed through their union under the Safety Committees and Safety Representatives Regulations 1977 or volunteer to be a Representative of Employee Safety under The Consultation with Employees Regulations 1996. The requirements of the two sets of regulations are similar and give the same facility to representatives; however, there are some differences with regard to those who are union appointed. The respective Unions and UNICAT H&S Unit can provide additional advice, if required.

The Interim Executive Board recognises the role of appointed Health and Safety Representatives. Health and Safety Representatives will be allowed to investigate accidents and potential hazards, pursue employee complaints and carry out school inspections within directed time but, wherever practicable, outside teaching time. They must be consulted on health and safety matters affecting all staff. They are also entitled to certain information, e.g. about accidents and to paid time off to train for and carry out their health and safety functions. However, they do not carry out health and safety duties on behalf of the Headteacher or LGB.

k. Fire Safety Co-ordinator

The Site manager is the Fire Safety Co-ordinator and shall attend the Fire Safety Co-ordinator training course and refresh this training every three years. The Fire Safety Co-ordinator is responsible for the local management and completion of day-to-day fire safety related duties, the upkeep and annual review of the fire safety manual. The Fire Safety Co-ordinator is to work within their level of their competence and seek appropriate guidance and direction from the Health and Safety Advisor and the local fire authority as required.

l. Legionella Competent Person

The Site manager is the nominated competent person for Legionella on the premises and acts on behalf of the Headteacher to provide the necessary competence to enable Legionella to be managed safely. He is to complete a Legionella training course every three years, and all training records are to be retained, including monitoring any contractors responsible for Legionella management.

The Legionella competent person will ensure that all periodic and exceptional recording, flushing, cleaning and general Legionella management tasks are correctly completed and recorded in accordance with the Legionella ACOP School and legislative requirements. They will advise the Headteacher of any condition or situation relating to Legionella, which may affect the safety of any premises users. They are to work within their level of competence and seek appropriate guidance and direction from the Headteacher and Safety Advisor as required.

m. Asbestos Competent Person

- i. The Site manager is the nominated competent person for asbestos on the premises and acts on behalf of the LGB to provide the necessary competence to enable asbestos to be managed safely.
- ii. He will ensure that all staff have a reasonable awareness of asbestos management and dangers. He is to ensure that the School Office staff are competent in the use of the asbestos register and that asbestos is managed in accordance with “The Control of Asbestos Regulations 2012” He will advise the LGB of any condition or situation relating to asbestos, which may affect the safety of any premises users.
- iii. They are to attend training every three years and all training records are to be retained. They are to work within their level of competence and seek appropriate guidance and direction from the Health and Safety Advisor as required.

n. Accident Investigator

The accident investigators are the Headteacher and Deputy Headteacher who will lead on all accident investigations in accordance with the school accident policy (MA1). They are to attend training every three years and all training records are to be retained.

o. Educational Visits Co-ordinator (EVC)

The EVC is Mrs S Cantini. She will receive refresher training every five years in line with recommendations

p. PEEP Lead

The Deputy Headteacher is the PEEP Manager.

q. Health and Safety Advisor

The Health and Safety Advisor for the school is **Portsmouth City Council**. As a chartered Health and Safety consultant they are able to provide advice on all aspects of health and safety related to schools. The Health and Safety Officer is to arrange for Portsmouth City Council to provide annual health and safety training as required.

The school also use the **University of Chichester** Health & Safety team for advice and support.

ARRANGEMENTS

The following arrangements for health and safety have been developed in accordance with the Management of Health and Safety at Work Regulations 2012. These arrangements set out all the health and safety provisions for Stamshaw Junior School and are to be used alongside other current school procedures & policies which are listed at Annex A.

Communication of Information: The Headteacher will ensure that systems are established so that staff and pupils are familiar with the arrangements set out in this policy.

All relevant up to date Health and Safety Executive Information and The Health and safety Law Poster is displayed in the staff room, along with the Trust’s and the Governors statements of intent.

Health and safety advice is available from the Headteacher and Deputy Headteacher.

In carrying out their normal functions, it is the duty of all leaders and staff to act and do everything possible to prevent injury and ill health to others, This will be achieved in so far as is reasonably practicable, by the implementation of these arrangements and procedures:

a. Health and Safety Assistance and Advice

Portsmouth City Council is the competent source of safety guidance for the school as required under Reg 7 of the Management of Health and Safety at Work Regulations 1999. Where incident, issues or concerns arise beyond the level of understanding or knowledge in the school then advice from the Health and Safety Advisor must be sought. Please see Annex B for a full list of roles and responsibilities.

The school also use the **University of Chichester** Health & Safety team for advice and support.

b. Accident Reporting & Investigation

For more information please see the school's First Aid policy,

Any accident, incident or injury involving staff, visitors or contractors is to be reported and recorded in the Accident Report Book held in the school office.

Children

If an accident does happen, resulting in an injury to a child, the teacher will do all they can to support the child concerned. We keep a first aid box by the Medical room (Site Managers Office). Accidents to pupils are to be recorded on the Record of Injury sheets located in the Medical Room. An up to date list of all first aid trained staff is kept in the Medical Room. The LGB are to annually audit the completed sheets which are kept by the Health and Safety Officer.

Any accident that is notifiable to the Health and Safety Executive (HSE) under the Reporting of Diseases and Dangerous Occurrences Regulations 2013 is to be reported using the F2508 Report Form found on the HSE website and **must be discussed with the Health and Safety Advisor** prior to online completion. (RIDDOR)

The LGB will annually audit the completed Accident Report sheets in order that repetitive casual factors may be identified to prevent recurrences. The completed Accident Reports are kept by the Health and Safety Officer.

Accidents involving children on the school premises that are considered to be of a more serious nature are to be recorded in the Accident Report Book which is kept in the Medical Room. **When a child has an injury of any nature to the head/face that are recorded in the Accident Report Book, parents are contacted at the time to inform them** to advise them of this. Parents will be always asked if they wish to come to see the injury.

Investigations

All significant accidents and incidents are to be immediately reported to the Headteacher. (Form Annex C) The accident investigator is to conduct a documented investigation into more serious incidents. Advice may be sought from the Health and Safety Advisor, especially if there are any difficulties in completing the accident investigation.

The purpose and intended outcome of the investigation is to identify the immediate and underlying causes of the accident so as to be able to implement appropriate measures to prevent reoccurrence.

The Headteacher will ensure that the LGB and the University of Chichester Academy Trust are appropriately informed of all incidents of a serious nature and the results of any subsequent investigation.

Premises hirers and community/third party users must report all incidents related to unsafe premises or equipment to the school staff, who will appropriately report and investigate each incident. Incidents related to the user's own organised activities are to be reported by them in line with their own reporting procedures.

Near Misses

Near Miss Report Forms are kept in a folder in the Medical Room. A copy of the Near Miss Report Form is at Annex D. Completed Near Miss Report Forms are investigated by the Health and Safety Officer, who will comment on proposed actions to rectify the problem. The forms are signed off by the Headteacher. Completed Near Misses are to be kept by the Health and Safety Officer.

Each term the completed Near Misses Report Forms will be reviewed in order that repetitive causal factors may be identified to prevent reoccurrences. The Finance and Resource Committee will review Near Misses to ensure that any actions taken have resolved the problems

C. Administration of Medicines

- i. For more information please see the school's Supporting Children with Medical Conditions policy,
- ii. The School Office will inform the class teacher when a child is required to take medicine.
- iii. One adult will check the administration of medication completed by another staff member. When the medication has been taken by the child, the Medicines Record sheet, kept in the Medical Room, is to be completed and signed.
- iv. For asthmatics who are able to take their own medication only one adult is required to supervise the child. The child and adult should initial the entry of the Medical Record sheet. If after ten puffs the child is not improving then the parents and hospital, if necessary, will be phoned.

Storage of Medicines.

Medicines are stored in a locked cupboard in the Medical Room. Where Medicines have to be refrigerated they are stored in a container in the medicine fridge in the Medical room. Inhalers are kept in the boxes in class. Epipens are stored in a locked cabinet in the Medical room and a red card system is in place to ensure these are immediately accessed when required.

d. Asbestos Management

- The Asbestos Register as issued by PBRs is kept in the School Office. The School Office staff are to ensure that the Asbestos Register is shown to all contractors who may need to carry out work on site. Contractors must sign the register as evidence of sighting, prior to being permitted to commence any work on the building.
- Any changes to the premises' structure that may affect the information in the Asbestos Register will be notified to PBRs in order that the Asbestos Register may be updated accordingly.
- Only the Site manager shall drill or affix anything to walls that may disturb materials and only after checking the Asbestos Register. Under no circumstances must other staff drill or affix anything to walls that may disturb materials,
- Any damage to the school buildings that is identified as containing, (or possibly containing) asbestos should be immediately reported to the Headteacher and the asbestos competent person who will immediately act to cordon off the affected area and contact the PBRs Asbestos Team for guidance. Any contractor suspected to be carrying out any unauthorised work on the fabric of the building should be immediately stopped from working and immediately reported to the Headteacher and asbestos competent person.

Training

- The Site manager, who is also the Asbestos Competent Person, is to attend an asbestos awareness training course every two years. The Health and Safety Officer is to record the training in the diary and file the certificates.

e. Child Protection

- Arrangements regarding child protection are set out in the Child Protection Policy.
- To help with preventing unsuitable people from working with children at Stamshaw Junior School the following will take place;
 1. **Disclosures**
 - All teaching staff are checked by the Disclosure and Barring Service (DBS). The Finance Manager initiates the procedure and keeps all disclosure records. Teachers are also checked against List 99
 - All staff are checked by the Disclosures and Barring Service (DBS)
 - University of Chichester Academy Trust staff who visit school are DBS checked and a list is provided to the school of these staff as approved visitors.
 - Governors and Parent Volunteers undergo a disclosure check based on the criteria set by the DBS.
 - Student Teachers are validated by the course provider.

- External Groups if they regularly carry activities at the school will undergo a DBS check. If the external group, only visit occasionally, a DBS check is not required, but they are supervised at all times while in the school.

2. **Recruitment**

Follow stringent UNICAT recruitment procedures. When recruiting new staff, the recruiting panel will ensure that one member has a valid certificate for the Safer Recruitment Workshop. This is presently the Headteacher and Deputy at Stamshaw Junior School

• **Guidelines**

All adults working with children are to follow these guidelines to safeguard children;

1. If working with a pupil on their own always ensure that the door is left open or that they can be visible to others.
2. No photographs are to be taken unless requested by the teaching staff
3. Do not exchange e-mails or text messages, or give out their own personal details to pupils.

• **Day and Residential Visits**

There are occasions such as day and residential visits when parent volunteers may be required to ensure that the ratio of adults to children meet the recommended guidelines or to provide one to one assistance:

1. Where groups of children will be with an adult out of sight of other groups the parent volunteers should have a DBS check.
2. Where groups of children will be in sight of each other parent volunteers do not require a DBS check.

f. Community Users

The Headteacher will ensure that:

- A risk assessment for the activity is completed using the Community Use Risk Assessment.
- The premises is safe for use and is always inspected prior to, and after each use.
- Means of general access and egress are safe for use by all users.
- All provided equipment is safe for use.
- Fire escape routes and transit areas are safe and clear of hazards.

g. Contractors on Site

- Where approved contractors may be required or selected for use then appropriate safe selection procedure are to be used to ascertain competence prior to engaging their services. The Safe Selection of Contractors Checklist to be used to determine competence of all contractors who will require adequate risk assessments to demonstrate their safe working practises for specific work being undertaken.
- All Contractors must report to the School Office, where they will be asked to sign in, sign the Asbestos Register and will be given safeguarding and emergency evacuation information. All contractors must be issued with the local written contractor induction brief that includes all relevant details of fire safety procedures and local safety arrangements.
- Contractors will be chosen from an approved list wherever possible
- The Site manager is responsible for monitoring work areas and providing appropriate supervision, especially where the contractor's work may directly affect staff and pupils on the premises.
- If contractors have to carry out work in areas that are recorded as having, or possibly, having asbestos then the contractor must provide a method statement and risk assessment. The work should normally be carried out by an asbestos trained person using appropriate personal protective equipment and methods for the safe working and disposal of any asbestos encountered.
- Any work involving dangerous equipment or machinery will always be done out of school times when children will not be present.

- It is the responsibility of the contractor to follow the Health and Safety Policy of the school at all times and to be aware of the emergency procedures involving evacuation and first aid. The school will provide the contractor with a copy of the schools Health and Safety Policy. Contractors must also read and sign the contractors H&S booklet kept in the admin office.
- The contractor must have written risk assessments to ensure pupil and staff safety during their period of work on the school site.
- All contractors working on site must have insurance cover which is compliant with the Trust's requirements. This must be forwarded to the school before any commencement of works.

h. Curriculum Activities

All safety management and risk assessments for curriculum based activities will be carried out under the control of the relevant teachers and subject teachers using the appropriate codes of practice and safe working procedural guidance for Design and Technology, Science, Music, Physical Education & Sport, Art, Swimming and Drama, as issued by CLEAPSS, HIAS and Hampshire County Council. Teachers and the appropriate subject teachers will be responsible for local risk management and ensuring that maintenance of equipment and premises in their areas of the curriculum are managed safely following the appropriate guidance.

We teach the children about health and safety in order to equip them with the skills, knowledge and understanding to enable them to live positive, successful and healthy lives. Teachers and Support Staff take every opportunity to educate children in this regard in the normal school curriculum.

We teach children respect for their bodies, and how to look after themselves. We discuss these issues with the children in PSHE lessons and we reinforce these points in Science and in Design and Technology, where children learn about healthy eating and hygiene. We also show the children how to move and play safely in PE lessons and in Sports Coach sessions.

Our school promotes the spiritual growth and welfare of the children through the RE curriculum, through special events such as harvest festivals, and through the daily act of collective worship.

Each class has the opportunity to discuss problems or issues of concern with their class teacher. Class teachers and the support staff use circle time to help children discuss and overcome any fears and worries that they may have. Teachers and Support Staff will always handle these concerns with sensitivity.

i. Defect Reporting Book

Any defects are to be reported immediately and recorded on site services or written in the defect reporting book which is situated in the front office. The Site manager will check the book daily. If the work cannot be carried out by the Site manager, then the site manager and Headteacher will arrange for a contractor to do the work following the Trust's procedures.

j. Display Screen Equipment

- The use of Display Screen Equipment (DSE) is to be managed in accordance with the Health and Safety (Display Screen Equipment) Regulations 1992 as amended by the Health and Safety (Miscellaneous Amendments) Regulations 2002. Though the majority of staff use DSE at school or on work at home the following users satisfy the criteria of using DSE as a **significant** part of their normal work: **Headteacher; Deputy Headteacher; Business Manager; Finance Assistant; IT Administrator; Attendance Officer; Admin Support Officer**
- Workstation assessments will be carried out annually for the designated DSE users using the VDU Workstation Checklist produced by the HSE. The Health and Safety Officer will provide guidance as required and ensure that any shortcomings as a result of the assessment are rectified.
- The Health and Safety Officer will file the completed VDU Workstation Checklists and record the dates in the diary.

- DSE users will be provided with a computer chair each having 360 degree swivel. Tilt function and adjustable height. Other aids such as footrests will be provided as required.
- Though not classified as DSE users, if required, class teachers have been provided with a computer chair to allow for easier changing of position without having to twist.

k. Electrical Equipment

- Electrical equipment in the school is to be used and maintained in accordance with the Electricity at Work Regulations 1989 (EAW). These Regulations apply to all work activities involving electrical equipment.
- **Before use** all portable electrical equipment should be checked **by the user** for damaged plugs and cables and loose or worn controls.
- Defective or suspected defective equipment systems of work, fittings etc. must be reported on site services and immediately taken out of use until repaired,
- PAT inspections – portable electrical equipment will be inspected and tested annually based on the HSE leaflet “Maintaining portable electric equipment in low risk environments” All Class 1 electrical items will be inspected annually. Class 2 electrical items will be tested every three years dependent on their use but no longer than 4 years. The Health and Safety Officer is to monitor the period that electrical equipment is tested by competent person and keep a record of all PAT tests for 6 years.
- Private electrical equipment **may not** be brought onto the premises and used **without permission** from the Headteacher. If equipment is within its warranty period, it may be used at school without being PAT tested. If it is out of its warranty period, it may not be used until it is PAT tested. The user of the equipment is responsible for checking plugs and cables and for its safe operation.
- The Finance Manager and Site Manager are to be informed about any new electrical equipment received into the school so that it can be added to future PAT testing schedules. New equipment will not be PAT tested while it is covered by a warranty.

I. Emergency Procedures

General emergency procedures are to be carried out in accordance with Stamshaw Junior School’s Critical Incident Plan. The Critical Incident Plan covers procedures for the evacuation of the school in the event of a fire, bomb warning or gas leak. Emergency procedures also cover attacks by a member of the public and accidents on day and residential trips.

Information

- All staff will receive a brief on the Critical Incident Plan at induction and they will be periodically provided with updated information as amendments are made to the Critical Incident Plan.

Evacuation

- If the building has to be evacuated the fire alarm will either automatically sound or will be manually activated using the fire alarm call points. The Assembly Point is on the playground. The evacuation of the building is to be practiced once each term.

The Emergency Bag

- The Emergency Bag, kept in the School Office, will normally be taken to the Assembly Point by the Admin Support Officer. If it still in the School Office when the Fire Marshals complete their sweep they will take it to the Assembly Point.

Malicious Attack

- In the event of a malicious attack, a lockdown procedure will be activated in which the outer doors will be closed, and classrooms will be locked until emergency services arrive or until sufficient information is available to decide on an evacuation plan. Orange Whistles (3 whistles and repeat) will be used to signal a lockdown procedure.

Day and Residential Visits

- In the event of an accident on a day or residential visit, information about the situation will be confirmed by the School Office staff and passed onto Headteacher. All parents will be informed through the website, email, telephone or Heart radio and parents of the children involved will be invited to the school to wait for further information. A School Emergency Management Team may be set up to deal with the situation.

Personal Emergency Evacuation Plans (PEEPS)

- PEEPS are to be completed for any person who may have difficulty in the event of an evacuation. Class Teachers are to ensure that classroom staff and volunteers are aware of any PEEPS to ensure a safe, assisted evacuation in the event of an emergency.

m. Fire Safety

Arrangements regarding fire safety are set out in the Fire Evacuation Policy and Fire Safety Manual. The Fire Safety Co-ordinator is the Site manager and is the immediate point of contact for all fire safety related enquiries on site.

Fire Evacuation Procedures

- Fire evacuation procedures are to be practiced at least once a term at different times and days. This is to make staff and children familiar with the sound of the alarm, the evacuation routes and the location of the Assembly point. It is also to give practice for the Fire Marshals in sweeping their areas.

The Fire Evacuation Drill Observation Sheet (2.3) is to be completed and actions taken to rectify any shortcomings. The completed observation sheet is to be kept by the Health and Safety Officer who is to record the date of the evacuation fire drill in the diary.

Training

- Fire safety information and procedures are included in the staff induction training.
- All staff should complete the annual fire safety refresher training.
- The Health and Safety Officer is to keep a record of all training undertaken and to record the dates in the diary.

Fire Safety Notices.

Fire safety notices are posted in the key areas of the building close to the fire points. They show evacuation routes and the Assembly Points.

Staff Responsibilities

Staff have a responsibility to know the location of fire points and fire exits. They should also know the location of the assembly point and how to get to it in the event of fire. Staff should be aware of the flammable potential of materials that they use and take the appropriate precautions and check the cable and plug of any portable electrical equipment before use. After its use staff should switch off electrical equipment. All PCs are to be shut down as staff leave classrooms.

Fire Marshals (Not applicable yet)

There will be a number of school staff who are trained as Fire Marshals. They have specific duties to carry out in the case of a fire evacuation.

Inspections and Tests

Inspections and tests are to be carried out as follows:

- Fire Alarm – checked weekly by the Site manager using a different fire alarm call point each week to activate the fire
- Fire Extinguishers – Checked monthly by the Site manager - serviced annually by a contractor.
- Fire Doors – checked monthly by the Site manager.
- Emergency Lighting – checked monthly by the Site manager – serviced annually by a contractor.
- Fire Alarm Monitoring Call Centre – the Site manager to check on the first Monday of the month that the Fire Alarm Monitoring Call Centre is to receive the signal.

Fire Manual

- The Fire Manual is to be reviewed annually by the Governors Finance and Resources Committee.
- The Risk Assessments are to be reviewed annually by the Fire Safety Co-ordinator and amended as new hazards or changes are identified.

Housekeeping

The corridors and doorways are to be kept free of rubbish and obstacles. The Site manager is to ensure that cleaners empty the paper bins daily and the outdoor bins are chained to the external fence away from the building.

n. First Aid

A First Aid Needs and Risk Assessment is to be completed by the Health and Safety Officer and reviewed annually by the Governors Finance and Resources Committee. Arrangements regarding first aid provision are set out in the First Aid Policy.

The Medical Room is situated next to the Headteacher's office. The Medicine Cabinet, First Aid box and a sink are situated in the Medical Room. One First Aid at Work trained First Aider should be available during the school day. The certificates of the names of the First Aid trained staff listed on the wall in the Medical Room.

First Aid should not normally be administered by anyone except First Aid trained staff with in-date training certification operating within the parameters of their training.

Minor cuts and abrasions sustained on the playground by children can be cleaned and a plaster put on by any member of staff. The incident is to be recorded on the Record of Injuries Sheet.

Where possible, TAs and LTs will be trained as Emergency First Aiders with refresher training provided every three years.

All bumps to the head/face area should be recorded in the Accident Report book which is kept in the Medical Room, and parents informed.

The inhaler boxes are to be taken on day or residential visits. The Admin Support Officer is to carry out the termly check and restock as required.

Asthma

Children who are asthmatic should have inhalers in school. All inhalers are kept in boxes in the Medical Room.

Suspected Serious Accident or illness.

- All staff are to be made aware of the procedure to be followed in the case of a suspected serious accident or illness, which is as follows;
- Keep calm. DO NOT move the injured person.
- Send for First Aider. This may be done using the internal phones and/or sending a child or adult to the School Office.
- Give comfort to the injured person.
- The First Aider will assess the situation and determine the next steps.
- If there is a serious accident an ambulance is to be called and parents informed immediately.
- If an accident requires hospital treatment, parents or emergency contacts are to be notified. In the absence of a parent, the First Aider and a senior member of staff is to accompany the child to the hospital and remain there until a parent arrives.
- An Accident Form is to be completed at the earliest opportunity.
- Incidents involving body fluids should be dealt with wearing disposable gloves.
- If there is a serious accident or there is an injury to the head of an adult the same procedures for children will apply and their next of kin will be informed.

- Children with known medical needs – all staff are made aware of these children and protocols are held in the First Aid room and a copy is given to the class teacher. Any specific training i.e. Diabetes management is arranged for the relevant staff

o. Gas

Gas leaks: Any member of staff discovering a suspected gas leak should make an informed judgement based on how strong the smell is as to whether they immediately evacuate the building and in case of emergencies telephone; 0800 111999 If there is a slight smell of gas, the first action should be to check that all gas appliances are switched off. This may clear the smell of gas. Windows should be opened. The boiler room is situated near the front door of the school. The boilers have the appropriate checks as required.

p. General Equipment

1. All general equipment requiring statutory inspection and/or testing on site (e.g. boilers, PE equipment, climbing apparatus) will be inspected by appropriate competent contractors.
2. Equipment is not to be used if found to be defective in any way. Defective equipment is to be reported to the Site manager and immediately taken out of use until repairs can be carried out or a replacement received.
3. The Health and Safety Officer is to keep all certificates and to record the inspection dates in the diary.

q. Good Housekeeping

Tidiness, cleanliness and efficiency are essential factors in the promotion of good health and safety. The following conditions are to be adhered to at all times;

- All corridors and passageways are kept free from obstruction
- Shelves in storerooms and cupboards are stacked neatly and not overloaded
- Floors are kept clean and dry, and free from slip and trip hazards
- Emergency exits, and fire doors are not obstructed in anyway (1 metre clearance)
- Supplies are stored safely in their correct locations
- Rubbish and litter are removed in the classrooms at the end of each working day, with waste control contractors removing weekly
- Poor housekeeping or hygiene conditions are immediately reported
- External waste contract for the disposal of medical waste

r. Hazardous Substances

The Control of Substances Hazardous to Health (COSHH) regulations aim to protect staff, pupils, visitors and contractors from substances that maybe harmful to their health.

- i. Where possible hazardous substances, materials, chemicals and cleaning liquids used by school staff and children should be replaced with non-hazardous equivalents. Where this is not possible a Contract of Substances Hazardous to Health assessment should be carried out by the COSHH Assessor. The Site manager is the COSHH Assessor.
- ii. The COSHH Assessor will list all hazardous substances used by the school staff and children and obtain the Data Sheets.

COSHH assessments will be carried out by the COSHH assessor and the record kept by the Health and Safety Officer. Any impact on working practices will be notified to all staff.

The following items have a COSHH Risk Assessment that may be used by teachers or TAs;

Sanitaire: Medical Room

Dishwasher tablets: Under staffroom sink cupboard

Daler Rowney Colourless Fixative: Site Manager's Locked cupboard (room 6)

Gold and Silver spray paint: Site Manager's Locked cupboard (room 6)

Staff should ensure that they are aware of the contents of the COSHH Risk Assessment if using any of the above items.

- iii. The Cleaning substances are stored in the cleaner's cupboard and the Site managers Cupboard.
- iv. No new substances that have a hazard warning sign are to be used by staff unless a documented COSHH assessment has been undertaken by the COSHH assessor, and the product has been approved safe use on site by the COSHH Assessor.
- v. When using a COSHH substance, staff must ensure that they follow the safe working practices and use the protective equipment identified in the COSHH Risk Assessment. If they are not clear about how to use the substance, then they are to ask the COSHH Assessor for assistance.
- vi. All Hazardous substances are to be stored in the secure and signed storage areas when not in use;
 - 1. Cleaner's cupboard next to toilets (17a)
 - 2. Cleaner's cupboard in the hall (3)
 - 3. Cleaners Cupboard in medical room (7)
 - 4. Cupboards in Site manager's room (AVU) Anti Vandal Unit room 37

These are to remain locked at all times. Dishwasher tablets shall be kept in the undersink cupboard in the Staffroom.

The COSHH Assessor shall attend a COSHH Assessor course every three years. The Health and Safety Officer will keep a copy of the certificate and record the training in the diary.

s. Health and Safety Diary (to be completed)

We diarise all aspects involving the management of Health and Safety, this ensures we are maintaining a high level of Health and Safety provision across the school and that all policies and risk assessments are updated and checks are completed. When these are done they are marked off in the H & S diary.

t. Hot Drinks

No hot drinks are allowed in classrooms, on the playground or in other areas of the building where there may be children during the day without the appropriate cup containing a sealed lid .

Inspections and Monitoring

- i. Monitoring and reporting are vital parts of the Health & safety culture as well as effective management systems and practices which ensure that risks are dealt with sensibly, responsibly and proportionately
- ii. Daily monitoring of the premises, through working routines and staff awareness, is expected to identify general safety concerns and issues which should be immediately recorded on site services and reported to the Site manager.
- iii. Monitoring and inspections of individual classrooms will be carried out by teachers and TAs.
- iv. Routine documented inspections of the premises will be carried out every half term using the Half Termly Premises Safety Checklist. Defects identified during these routine documented inspections are to be recorded in the Defect Report Book. Any identified high-level risks or safety management concerns are to be actioned by the LGB.
- v. Annual detailed inspections of the premises' safety management system will be carried out each year by members of the LGB. These documented inspections will examine all areas of the safety management system and will be carried out using the Annual Health and Safety Inspection Checklist. It will be carried out as a rolling inspection with some elements inspected each term.
- vi. The University of Chichester Academy Trust carry out Health and Safety Audits on an annual basis.

u. Kitchens

a. Main kitchen

The main kitchen is only to be used by authorised staff in accordance with the identified safe working procedures. Authority and responsibility for those procedures for local management of the main

kitchen is Caterlink. Any persons not normally authorised but wishing to enter the kitchen area must gain approval from the staff prior to entry and must strictly adhere to the kitchen safe working practices.

b. Curriculum D&T Kitchen Area

All children using the kitchen shall be supervised in accordance with the Risk Assessment.

v. Legionella Management

General

Legionella is a generic term of bacteria (legionellae) which is common in natural and artificial water supplies. It thrives at temperatures between 20° C and 45° C.

Managing the Risk

The Headteacher will:

- Appoint a competent person with sufficient authority and knowledge of the installation to help take the measures needed to comply with the law.
- Ensure that suitable and sufficient training is provided to members of staff nominated as the competent person and for those who carry out the monitoring checks.
- Ensure that records of all related training, flushing, temperature monitoring, cleaning and defects are to be retained for auditing purposes.

The Legionella competent person will manage and undertake all procedures regarding Legionella in accordance with Legionella Approved Code of Practice (L8) and HSE274.

- Risk Assessment
 - The Legionella competent person will annually review the Legionella Risk Assessment or at any time that building works may change the hazards or risks. They are to identify and assess sources of risk which includes checking whether conditions will encourage bacteria to multiply; water temperatures is a between 20 – 45°C, if there are 'at risk' susceptible people who may be exposed to contaminated aerosols.
- Control and Monitoring

The Site manager is to carry out and record the results of the following control measures;

1. When flushing hot and cold water sources they are to be flushed for at least two minutes at a reasonable flow rate.
2. Weekly flushing for low use hot and cold water sources identified including; Disabled toilet
 1. Flush all taps and water sources after half term or end of term holidays.
 2. Remove and descale the shower heads every 3 months using the supplied descaler. (N/A)
 3. Descal taps as required.
 4. Regular checks on the water temperature for the cold and hot water sentinel taps as shown the schematic drawing of the school water systems

- Record Keeping
 1. The Site manager is to record all the results on the appropriate forms;
Legionella Temperature Monitoring Record Form – Annex
Legionella Flushing Record Form – Annex
Legionella Controls – Additional – Annex
 2. The Site manager is to keep a record of all the Legionella Checks.
 3. Training

The Site manager and Health and Safety Officer are to attend a Legionella training course every three year. Appropriate training will be provided for any new measures that are introduced to control legionella.

X. Lone Working

All lone working is to be approved by the Headteacher and Site manager, and is to be carried out in accordance with the premises Lone Working Risk Assessment and the local written procedures

Wherever possible lone working is not to take place. Arrangements should be made so that more than one person is in school at the same time.

- i. Where non key holders need to come into school it will be arranged for the Site manager, Headteacher or Deputy Headteacher to open and close the school.
- ii. If key holders are required to open and close the school themselves they will need to have arranged with a third party a time when they should have returned home so that the Site manager can be contacted to check the school if the member of staff does not return home.
- iii. If any electrical equipment is used it should be turned off after use.

Y. Mobiles Phones – Possession and use

Mobiles phones are a part of modern society. It is the school's responsibility to promote the safe and responsible use of mobile phones.

Mobile Phones in schools present a number of challenges. These include:

- Mobile phones interrupting lessons and disrupting the learning of others
- Possible theft of mobile phones
- The ever increasing sophistication of mobile phone technology which increase the possibilities of inappropriate use.
- The use of mobile phones for cyber bullying.

Children should not bring mobile phones to school except in circumstances previously agreed with the Headteacher. If they are bringing them in, they need to be kept at the office for the course of the school day.

Z. Moving and Handling

- i. All staff must complete the moving and handling refresher course every 2 years.
- ii. Staff are not permitted to regularly handle or move unreasonably heavy or awkward items, equipment or children unless they have attended specific moving and handling training and/or have been provided with mechanical aids in order to work safely.
- iii. Any significant moving and handling tasks are to be specifically risk assessed in order that training requirements and mechanical aids can be accurately determined to ensure that the task is carried out safely.
- iv. The Site manager is expected to undertake regular physical work which would typically include significant moving and handling. They will attend a formal moving and handling course specific to the work requirements.

AA. Off-site Activities

- i. Arrangements regarding off-site activities are managed in accordance with the Outdoor Education Service's procedures and guidance which are located on the Hampshire Evolve System Advice can be given by the trained Outdoor Leaders.
- ii. Risks assessments should be looked at before the activity takes place to ensure that the appropriate hazard control measures are instigated. A generic risk assessment may exist such as walking around the local area, adapted for specific children as appropriate. If the activity requires a new risk assessment speak with Health and Safety Officer or one of the Risk Assessors. A list of Risk Assessments is at Annex K.
- iii. All risk assessments for offsite visits must be uploaded to the Evolve website and be authorised by the EVC or Headteacher. **All activities considered adventurous must be submitted to Evolve at least 6 weeks in advance of the trip in order to gain approval from Hampshire.**

- iv. We only use coaches and minibuses where seat belts are provided. The pupils are always instructed to use the seatbelts and checks are carried out before the departure of the vehicle.
- v. All educational visits must follow the requirements of the School Educational Visits policy. We have an SLA for Outdoor services and we use HCC Evolve programme to record all visits off site.

BB. Physical Intervention

Arrangements regarding physical intervention are set out in the Positive Handling Policy. Physical intervention is defined as;

a) Physical Contact

Situations in which proper physical contact occurs between staff and pupils e.g. in games or P.E., or in the supervision of children. It may be appropriate to hold the hand of a child if the child is very distressed or ill. At all times members of staff will act as a responsible parent would.

a) Physical Intervention

This may be used to divert a pupil from a destructive or disruptive action, for example guiding or leading a pupil by hand, arm or shoulder with little or no force.

b) Restrictive Physical Intervention

This will involve the use of reasonable force to physically intervene when there is;

- a. An immediate risk to pupils or staff or
- b. A risk of significant damage to property.

All such incidents will be recorded in the Serious Incident File and on the Record of Restraint/Physical Intervention Form. A copy of this is to be placed in the pupils' file with another copy in the Restraint/Serious incident File in school.

CC. Provision of Information

- 1) The Headteacher will ensure that information systems are established so that staff are periodically provided with information regarding safety arrangements on the premises. These systems are PDM, staff briefings, e-mail and training days.
- 2) When staff attend training sessions or have read key documents they are asked to sign to say they understand their duty, roles and responsibilities, a copy of this is kept in the office of the Deputy Headteacher.
- 3) Information for volunteers and parents is through induction training, meetings, newsletters, the school website and the school Facebook page.
- 4) Contractors will have information given to them at the planning meetings before they start; leaflets on safeguarding and fire evacuation will be given out by the Site manager when on site.
- 5) Local health and safety advice is available from the Health and Safety Officer, and the school health and safety advisor can provide both general and specialist advice.
- 6) There is a Health and Safety Board located in the staffroom on which the Health and Safety Law poster and other safety related information is displayed.
- 7) Policies and other key documentation can be located on the shared drive.

dd. Risk Assessments

- 1) General risk assessment management will be co-ordinated by the Health and Safety Officer and when required in consultation with the school Health and Safety Adviser. Risk assessments must be undertaken for all areas where a significant risk is identified or a possibility of such risk exists.
- 2) The Health and Safety Officer will ensure that there are a minimum of two risk assessors. They will keep a copy of the course certificates and records their training dates in the diary.
- 3) The school has trained risk assessors who will oversee the correct completion of risk assessments as appropriate. Risk assessments will be carried out by all staff, for classroom, curriculum and off-site

activities. Staff that have the appropriate knowledge and understanding in each area of work will oversee the content.

- 4) All risk assessments and associated control measures are to be approved by the Headteacher or their delegated member of staff prior to implementation.
- 5) The Health and Safety Officer will file the completed risk assessments and place a copy on the school network in shared drive/Health and Safety. Risk assessments will be reviewed periodically in accordance with each risk assessment's review date as listed for review in the school's bring up diary system maintained by the Health and Safety Officer. A list of Risk Assessments is at Annex K The Risk Assessment template can be found in Annex L

ee. Security

- 1) Arrangements regarding security are based on the premises security risk assessment and are set out in the on-site security policy and procedures, which include emergency and unlock routines.
- 2) All visitors to the school must read the safety and security information situated at the front of the School Office, sign to say they have read the leaflet and signed in, including all reps.
- 3) Though there is doorbell access to the reception area, entry into the school is controlled by administration staff. Only staff and, where necessary, trusted visitors have the fob for entry into the site.
- 4) Keyholders – please see Annex M for a full list.
- 5) Pedestrian gates are to be closed during the school day. They are only to be opened for specific activities and approximately five minutes before the children finish in the afternoon.
- 6) We require all adult visitors and volunteers to the school who arrive on site between 7.30am. and 6pm. to sign in at the reception area, and to wear a security identification badge at all times whilst on the school premises. (Red or green lanyards dependent upon whether the school has seen a copy of a DBS: in line with Trust policy) Staff and Governors all have personal identification security badges with photo portraits on.
- 7) Teachers and Support Staff will not allow any adult to enter their classroom if the school visitor's badge does not identify them. Visitors and volunteers without security badges will be challenged. The school's diary (Outlook) gives all staff accurate information about the visitors expected in school. There is also the master diary to refer to.
- 8) If any adult working in the school has suspicions that a person may be trespassing on the school site, they must inform the Headteacher or Deputy Headteacher. The Headteacher or Deputy Headteacher will warn any intruder that they must leave the school site straight away. The Headteacher, or nominated representative, will contact the police to notify them of the incident if there are any concerns that an intruder may cause harm to anyone on the school site. This includes anyone displaying aggressive behaviour.

ff. Smoking

Smoking is not permitted on the premises. This includes e-cigarettes and vapes.

gg. Stress and Wellbeing

- 1) Stamshaw Junior School is committed to promoting high levels of health and wellbeing and recognises the importance of identifying and reducing workplace stress.
- 2) Stress management through risk assessment and appropriate consultation with staff will be periodically reviewed and acted upon in accordance with the current Health and Safety guidance and requirements.
- 3) On-site arrangements to monitor, consult and reduce stress situations are through staff meetings and periodic training.

hh. Traffic Management

Arrangements regarding on-site traffic safety are based on the premises traffic risk assessment should include;

- 1) The Car Parking entrance is separate to pedestrian entrances. Pedestrian gates are opened at the start and end of the school day.
- 2) No parent is allowed to park or turn in the staff car park, unless previously agreed with the Headteacher.
- 3) Waste management visits are organised on a specific day of the week. (Mon & Weds)
- 4) Periodically the Headteacher views the surrounding area to evaluate traffic flow.
- 5) Traffic Wardens, Police and community liaison officers are a periodic presence.

ii. Training

- 1) Health and safety induction training will be provided and recorded for all new staff/volunteers in accordance with the Staff Health and Safety Induction Checklist.
- 2) The Headteacher is responsible for ensuring that all staff/volunteers are provided with adequate information, instruction and training regarding their safety at work. Training needs will be discussed at performance review and a health and safety training plan will be developed and maintained to ensure health and safety training is effectively managed for all staff who require it.
- 3) All staff will be provided with the following as a minimum training provision;
 - Induction training regarding all the requirements of this health and safety policy.
 - Appropriate local training regarding risk assessments and safe working practices
 - Updated training and information following any significant health and safety change
 - Specific training commensurate to their own role and activities
 - Periodic refresher training that will not exceed three yearly intervals
 - Appropriate annual refresher courses to meet ongoing training requirements

jj. Violent Incidents

- 1) Violent, aggressive, threatening or intimidate behaviour towards staff, whether verbal, written, electronic or physical, will not be tolerated at Stamshaw Junior School
- 2) Staff must reported all such violent and aggressive incidents to ensure that there is an awareness of potential issues and/or injuries. This is to enable incidents to be appropriately investigated so that reasonable actions may be taken to support those involved and reduce the risk of similar incidents occurring in the future.
- 3) Violent incidents recording is completely confidential. Violent and aggressive incidents are to be recorded and held by the Health and Safety Officer.

kk. Visitors

- 1) All visitors must initially report to the School Office where they will be provided with the key health, safety and fire safety information to enable them to act appropriately and safety in the event of an incident.
- 2) Visitors to the premises will be provided with emergency evacuation information, they will be issued with a school visitor's badge even if they are wearing their organisation's security badge and will be required to sign the visitor book. Staff who are known to have a DBS check will have a green lanyard and visitors where this is not known will be given a red lanyard and be accompanied around the site.

ll. Welfare facilities

The School will undertake to ensure compliance with the relevant legislation with regard to welfare provision for all pupils and staff and to ensure best practice extending the arrangements as far as is reasonably practicable to others who may also be affected by our activities. In particular the following facilities will be provided;

1) Toilet and Washing facilities

- a) Toilet facilities and washrooms for staff are separate from those provided for pupils. Facilities are provided for disabled people in the separate disabled toilet
- b) Separate toilet facilities are to be provided for male and female pupils. The ratio of toilets and washbasins to pupils will be at least as required by Statutory Instrument No 2 'The Education (School Premises) Regulations 1999 and School Premises (England) Regulations 2012.
- c) Sufficient toilet and washing facilities for staff, in accordance with Approved Code of Practice, are provided near the School Office and near the staffroom.
- d) Facilities will be kept clean, adequately ventilated and lit. Washing facilities will have running hot and cold or warm water, soap and paper towels.
- e) Shower and washing facilities are to be cleaned, maintained and flushed in accordance with guidance in the Legionella Approved Code of Practice (L8) and HSE274.

2) Provision of Drinking Water

An adequate supply of drinking water will be provided by;

- a) Drinking water stations throughout the school
- b) Taps – designated cold taps in the school provide drinkable water
- c) Pupils bring in their own bottled water and are able to refill during the day.

3) Accommodation for Clothing and Facilities for changing

- a. PE bag and PE clothing boxes are provided for changing
- b. Pupils change for PE in classrooms, when relevant the blinds are shut.
- c. Adult toilet areas are available for staff to change for PE

4) Pupils Meal Facilities

- a) The Children having school meals or packed lunches eat in the school hall and are to be supervised by members of staff
- b) Sometimes it is necessary to change usual practice, therefore, occasionally, the children may be in classrooms or outside. Both temporary canteens, outside and in classrooms, will be supervised by members of staff

5) Staff facilities for rest and to eat meals

A staff room with hot beverage facilities as well as a water cooler (fridge) and sink. A Microwave and refrigerator is provided for the use of school staff and volunteers as a rest and eating area.

mm. Work Equipment

- a. **Definition.** Work equipment is any machine, appliance, apparatus or tool used at work by a member of staff in order to carry out their assigned tasks. It includes any new, second-hand, leased or hired equipment. The use of the equipment includes any activity such as starting and stopping equipment, repair, maintenance, servicing and cleaning.
- b. **Management.** The Headteacher will:
 - a. Ensure that risk assessments are carried out.
 - b. Approve the proposed acquisition of all work equipment and ensure that it meets any required specifications (e.g. British Standards).
 - c. Ensure that appropriate staff training is provided.
- c. **Information, Instruction and Training**
 - a. The Headteacher will make arrangements for suitable induction training for staff that includes the use of any work equipment involved in their job before they use any such equipment. Any staff issued with new work equipment, or a change of task that involves different work equipment, must have appropriate training and given instructions to ensure a full understanding of the use, adjustment and care of the equipment. A record of all training given will be maintained.

d. Appropriate Supervision.

- a. The Headteacher will provide supervision where any workplace activity or task involving work equipment has been identified as being in need of some specific on-the-job instruction and training. The person appointed must be competent in all aspects of that supervision.
- b. Supervision is provided for all young persons using work equipment and for anyone else who through unfamiliarity with the working environment or some kind of disability needs extra care and attention to ensure their health and safety.

e. Staff Responsibility.

Staff have responsibility to co-operate by:

- a) Attending relevant training, and using work equipment for its proper purpose following any recommended procedures and instructions issued to them.
- b) Reporting any loss or defect of work equipment.
- c) Not tampering with or altering work equipment in any way which may inhibit its effectiveness.
- d) Not introducing into the workplace, or using, any unauthorised equipment or spare parts.
- e) Helping to keep work equipment clean and in good condition by treating it with respect and care.
- f) Reporting all accidents and near misses.

f. Selecting Suppliers

- a. Wherever possible work equipment should be purchased using suppliers approved through UNICAT.
- b. The Headteacher will ensure that any equipment purchased from external suppliers is fit for the intended purpose and complies with the appropriate Standards.

g Maintenance of Work Equipment

- a) A key aspect of providing safe work equipment for staff to use is the arrangement of suitable maintenance:
 - i. Electrical Equipment – PAT inspection
 - ii. Access Equipment - Termly inspection
 - iii. Step stool and step ladders – Annual inspection
 - iv. Other Equipment – user inspects prior to use.
- b) Where possible work equipment will be maintained under Service Level Agreements using contractors listed in the County Supplies Maintenance and Repair Contracts Directory.
- c) Staff are not allowed to carry out maintenance tasks without appropriate training and instructions.
- d) Any work equipment that is defective or not fit for purpose is to be removed from use and the Site manager informed.
- e) The Site manager will maintain records of work equipment (MA20)

nn. Work at Height

- 1) Work at height is always to be undertaken in accordance with the HSE Guide to working at height regulations. A copy can be found on the Health and Safety board. At Stamshaw Junior School, general work at height will be undertaken in accordance with the on-site generic risk assessment for work at height which identifies general requirements and safe working practices. Specific or higher risk tasks will be out carried in accordance with a specific risk assessment for that task.
- 2) The competent person for work at height on the premises is the Site manager. He is to attend a Ladder & Stepladder training course every three year.
He is authorised to:
 - a) Use step stools, stepladders and leaning ladders in accordance with training.
 - b) Carry out periodic inspections of all on-site ladders, stepladders and steps tools.
 - c) Remove access equipment from use if defective or considered inappropriate for use.

- 3) No members of staff are permitted to use any access equipment for work at height without specific training.
- 4) Work at height on the premises is only permitted to take place under the following conditions:
 - a) Any work to be carried out at height must be underpinned by a risk assessment.
 - b) Access equipment selected for work at height must be in accordance with the risk assessment.
 - c) Any staff working at height must be appropriately trained to use the access equipment normally stepladders or step stools.
 - d) Any safety concerns about a work at height task must be raised prior to work starting.
- 5) Staff are not to improvise or use alternative access methods of their own choice. Use of any furniture including tables and chairs is forbidden for any work at height.
- 6) Staff may only use leaning ladders if they have personally attended the Ladder & Stepladder Safety half-day course and are currently in-date.
- 7) Access equipment used on site such as ladders and stepladders must only be that provided. They are never to be lent to, or borrowed from third parties or contractors.
- 8) Contractors working at height are to be appropriately supervised and must only use their own access equipment.

ANNEX**a. List of roles and responsibilities.**

Task	Name of person responsible	Job title of person responsible
H&S Policy review	R Jones	Headteacher
H& S Advisor	Portsmouth City Council	
Finance & Resources committee	LGB	LGB
Communication and information management	R Jones	Headteacher
Critical Incident Management	R Jones	Headteacher
H&S Induction Training	S.Cantini / M Bond	Deputy Headteacher/ Site manager
Programmed updating training	S Cantini M Bond	Deputy Headteacher Site Manager
Planned checks (procedures)	R Jones	Headteacher
Planned checks (equipment)	M Bond	Site Manager
Planned checks (premises)	M Bond S. Cantini	Site manager Deputy Headteacher
Incident reporting/investigation	R Jones/ S Cantini	Headteacher/ Deputy Headteacher
Coordination of risk assessment work	S Cantini	Deputy Headteacher
Fire procedures including personal emergency evacuation plans	S. Cantini M Bond	Deputy Headteacher Site Manager
Locally organised premises maintenance, repair and improvement	R Jones/ M Bond	Headteacher / Site manager
Electrical Testing (PAT)	M Bond	Site Manager
First Aid (training and equipment)	A Smith	Admin Support Officer
Vehicle control and pedestrian safety	M Bond	Site manager
Educational visits coordinator (EVC)	S Cantini	Deputy Headteacher
Stress and Wellbeing	R Jones / S. Cantini	Headteacher/ Deputy Headteacher
Child Protection Lead	R Jones/ S Cantini	Headteacher/ Deputy Headteacher
Supporting pupils with medical needs	A Smith	Admin Support Officer
Premises Security	R Jones/ M Bond	Headteacher / Site manager
Contractors on site	M Bond	Site manager
Outside lettings	N Glover	Finance Manager
Asbestos Log update / review	M Bond	Site manager
Electronic Back up of Admin & Curriculum Network	RM & K Palmer-Roach Drift	IT Administrator
E-safety Co-ordinator	D Barrand	Computing Lead

b. Investigation form**Stamshaw Junior School Accident Report**

School	Stamshaw Junior School
Reference Number (Sch)	001

Injured Person's Name	
Injured Person's Address	
Age of Injured Person	

Date of Accident		
Time of Accident		
Location of Accident		
Nature of Injury		
Was Activity Permitted	Yes	No

Description of Accident	Description of Accident Insert description of accident & include photos or a plan if appropriate

Post-Accident Action	Tick any boxes that reflect the actions taken following the accident	
First aid provided	<input type="checkbox"/>	<input type="checkbox"/>
Ambulance called	<input type="checkbox"/>	<input type="checkbox"/>
Parents contacted	<input type="checkbox"/>	<input type="checkbox"/>
Repairs arranged	<input type="checkbox"/>	<input type="checkbox"/>
Equipment taken out of use	<input type="checkbox"/>	<input type="checkbox"/>
Area isolated	<input type="checkbox"/>	<input type="checkbox"/>
Accident Book Report Form completed for staff if also injured (if appropriate)	<input type="checkbox"/>	<input type="checkbox"/>
Reported to the HSE/RIDDOR (if appropriate)	<input type="checkbox"/>	<input type="checkbox"/>
Risk assessment reviewed (if appropriate)	<input type="checkbox"/>	<input type="checkbox"/>

Accident Consequence	Person absent from school?	Yes	No
----------------------	----------------------------	-----	----

Details of Witnesses	Name of any witnesses and addresses (if appropriate)

Additional Information	Insert optional information that may be relative to this accident

Report Completed By	
Designation	
Signature	
Date	

c. Near miss form



Stamshaw Junior School Near Miss Report

School	Stamshaw Junior School
Reference Number (Sch)	001

Injured Person/s Name/s	

Date of Incident			
Time of Incident			
Location of Incident			
Nature of Incident	Racial	Road traffic incident	Verbal/Physical assault
	Bullying	Health Concerns	Behaviour/ discipline
	Injury	Environmental	Near miss/dangerous occurrence
Was Activity Permitted	Yes		No

Make & registration of any vehicle involved	
Description of Incident	Insert description of incident (incl. equipment, what what said & by whom) & include photos or a plan if appropriate

Details of Witnesses	Name of any witnesses and addresses (if appropriate)

Post-Incident Action	Tick any boxes that reflect the actions taken following the incident and by whom	
	Tick	Who
First aid provided		
Ambulance called		
Parents contacted		
Repairs arranged		
Equipment taken out of use		
Area isolated		
Accident Book Report Form completed for staff if also injured (if appropriate)		
Reported to the HSE/RIDDOR (if appropriate)		
Risk assessment reviewed (if appropriate)		
Additional Information	Insert optional information that may be relative to this incident	

Report Completed By	
Designation	
Signature	
Date	

d. Lockdown procedures

Lockdown procedures will only be activated where there is a serious threat from an intruder on the school premises or local incident (such as toxic fumes) within the vicinity of the school.

Lockdown will be activated when it is considered safer than evacuating and dispersing pupils.

Please familiarise yourself with the following procedures:

RUN/TELL/HIDE

- Lockdown will be signalled by blowing of whistle (3 blasts, count to 3, 3 blasts, count to 3...) once an adult hears the whistle, they will blow their whistle in same timing
- Check the immediate corridor or halls and get all pupils and staff into the closed classrooms or safe areas. Optional safe areas for pupils being educated in the large Hall is the Kitchen, or stage area. For the small hall it is the DT room or the music room.
- Keep all pupils in their classroom until given the all clear.
- Doors should be locked if possible, or the door should be wedged closed, shut windows and blinds. Turn off lights if necessary.
- Keep pupils seated and away from doors and windows. There may be circumstances when it is best to sit on the floor or under desks.
- Teachers will maintain (as best they can) a calm atmosphere in the classroom and keep alert to the emotional needs of pupils.
- Try and keep pupils engaged in a quiet activity or game.
- Do **not** allow anyone out of the classroom during a lockdown procedure in any circumstances.
- Teachers should remain with their pupils at all times.
- If the teacher is out of class at the time of the incident then they should attempt to go back to the classroom **IF SAFE** to do so. However, if this is too risky or dangerous then they must try and make contact with the children as soon as possible.
- The Headteacher, Deputy Headteacher, office staff and other non-teaching staff who can be safely assembled, should form a School Incident Management Team and start to follow the critical incident flow chart.
- Parents should not be allowed to pick up their children during a lock down procedure.
- A lockdown drill will be carried out with staff annually.

If the children are outside, teachers/supervisors should, depending on the situation, either move them to the nearest room or building that can be secured, or ask them to hide, disperse or take cover.

The following acronym will support with remembering the procedures to follow

'CLOSE'

Close all windows and doors

Lock up

Out of sight & minimise movement

Stay silent & avoid drawing attention

Endure- be aware you might be in lockdown for some time

e. Fire Evacuation Policy

Stamshaw Junior is fitted with an automatic fire detection system with after-hours remote monitoring and automatic fire doors, manual call points are also located by all external doors.

Fire notices are displayed in every room with evacuation procedures by all external doors.

Premises evacuation is signalled by a two tone siren in the main building and a continuous bell in the community building. In the event of the alarm sounding all staff must calmly and quickly escort all pupils and visitors out of the building, following the designated evacuation routes; mustering at the assembly point in the main playground (see premises evacuation plan).

On vacating the building if you are the last person you must shut the door behind you, teachers must insure class room doors are closed.

If a fire is discovered proceed to the nearest external exit and activate a manual call point, and then follow the premises evacuation plan to reach the assembly point.

In the event of an evacuation, the Headteacher and site manager are the designated fire coordinators and will oversee the evacuation of the building. Fire marshals will aid the evacuation.

Under no circumstances can staff re-enter the building without direct approval from the fire co-ordinators.

The fire co-ordinators are responsible for checking the building has been evacuated and investigating the cause for the alarm. Hampshire Fire and Rescue must only be contacted once there is confirmation of an actual fire; this will be carried out by an inspection of the area of activation.

When fire co-ordinators and or marshals re-enter the building they must have radio communication with each other and the muster point.

If on investigation a fire is confirmed the fire co-ordinators will immediately vacate the building and contact Hampshire Fire and Rescue. Once Hampshire Fire and Rescue are on site the fire co-ordinators will liaise with the duty fire officer and then hand the incident over to them.

Fire extinguishers are sited around the building; extinguishers are designed only to be used to aid your escape from the building, they should not be used to tackle the fire. The fire co-ordinators may decide to deploy an extinguisher in the event of discovering a minor fire as long as it is deemed safe to do so.

The main Fire control panel is located in the School Office.

The following procedures are undertaken:

- All external fire doors are unlocked daily by the site team as required and as per the locking and unlocking procedures.
- External fire doors must not be locked until the building is being secured for the day.
- Escape routes are checked daily by the site team.
- Fire Extinguishers are maintained and checked weekly by the site team.
- Emergency lighting is checked weekly by the site team.
- Fire alarms are tested weekly by the site team; this test is carried out every Friday at 08:00.
- Full Emergency evacuation procedure will be tested once every term.

All of the appropriate checks are recorded in the Fire Log Book; these records are maintained by the Site manager and overseen by the Health & Safety Officer

Stamshaw Junior School

CLASSROOMS—BLUE
 OFFICES—RED
 OTHER AREAS—GREEN
 TOILETS—ORANGE

- FIRE PLAN**
- 1 Room Numbers
 - Smoke Detectors
 - Call Points
 - ⊕ Extinguishers/Blankets

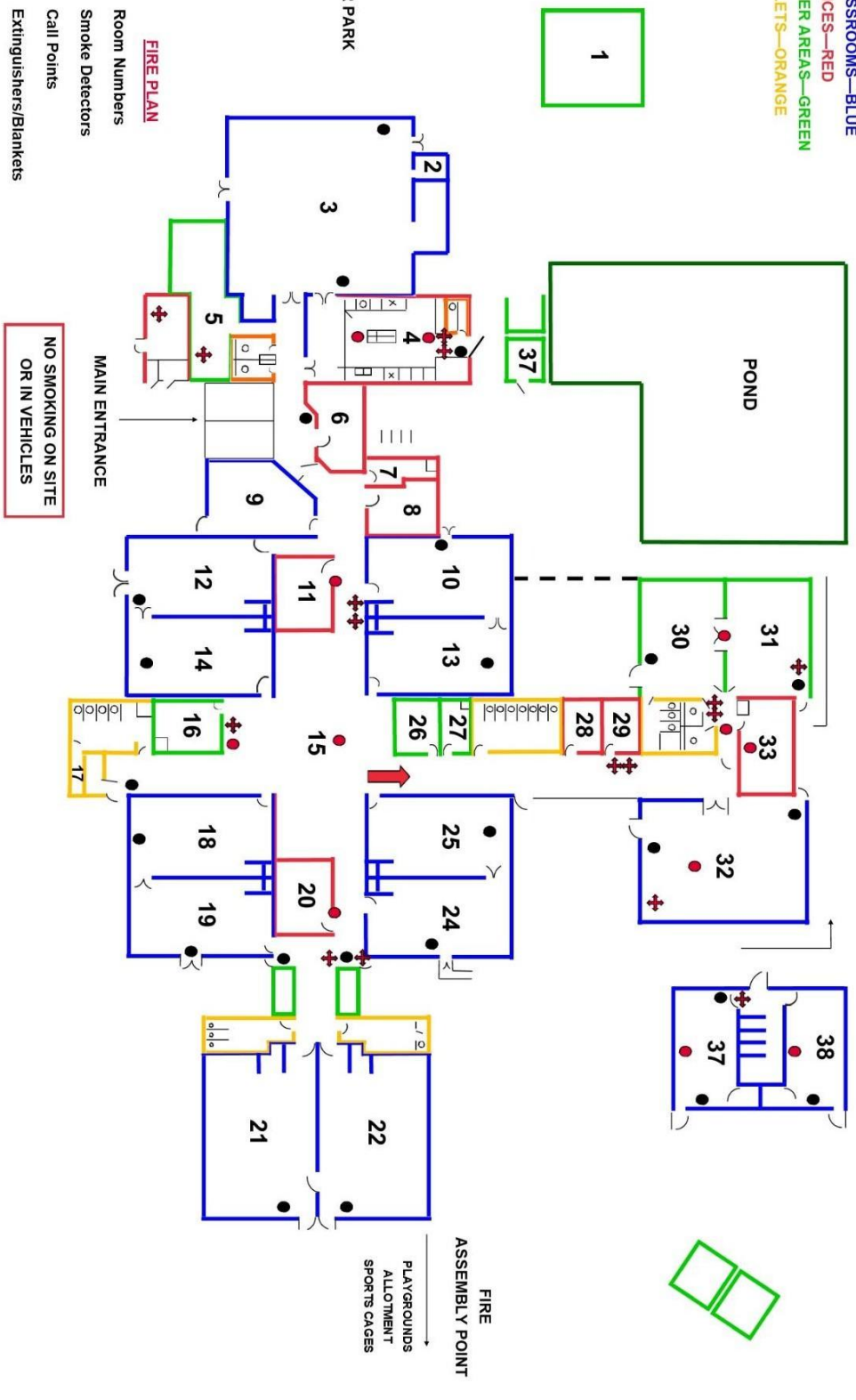

f. Premises safety checklist

Premises Health and Safety Check for School Caretakers and Building Managers.

School**Stamshaw Junior School**

Period covered: to **20**.....

If no defects / concerns are found / noted please indicate this in the box as: **'NIL'**

Perimeter Fencing and Gates

(Damage caused by inclement weather / vandalism / ageing etc)

Defects / concerns:

Car Park

(Surface damage eg. potholes / other)

Defects / concerns:

Footpaths and hand rails

(Raised paving, damage, slip hazards, defects etc)

Defects / concerns:

Play Ground / Yard Areas

(Damage to floor surface / equipment etc)

Defects / concerns:

Playing Field

(Damage caused by inclement weather / Vandalism, litter, wear and tear etc)

Defects / concerns:

School Safety and Security systems

(alarms, shutters, other safety / Security equipment etc)

Defects / concerns:

Doors and Windows

(Signs of damage to doors, windows, restrictors etc)

Defects / concerns:

Corridors and Stairs

(Trip, slip and fall hazards, articles blocking walkways, fire exits etc)

Defects / concerns:

Classrooms

(trip and slip hazards, faulty equipment, clear entry and exit points etc)

Defects / concerns:

Storage Areas

(Articles and substances stored safely, doors secured to restrict access where appropriate etc)

Defects / concerns:

Staff Room

(Trip and slip hazards, faulty equipment, safe storage, fire risks etc)

Defects / concerns:

Electrical equipment

(Portable and fixed appliance testing up to date / damage etc)

Defects / concerns:

Fire Safety

(Adequately located, storage, correct type, serviced extinguishers, fire doors in good order, fire exits clear, signage etc)

Defects / concerns:

Legionella and Asbestos

(Management Systems and checking schedules being adhered to etc)

Defects / concerns:

Any other defects / concerns / condition observations etc

Caretaker / Site Managers Comments and action taken:

Name of Caretaker / Site Manager:

Signature:

Date report submitted to Headteacher:

Action taken by Head Teacher / Responsible Person:

g. Legionella Temperature monitoring form

M / Y	LOCATION	DEVICE	LOC	H/C	CODE		JAN	FEB	MAR	NOV	DEC
Y	KITCHEN	SINK	4	HOT	0.16						
Y	KITCHEN	SINK	4	COLD	0.16						
Y	KITCHEN	SINK	4	HOT	0.18						
Y	KITCHEN	SINK	4	COLD	0.18						
Y	KITCHEN W/C	WHB	4	HOT	0.20						
Y	KITCHEN W/C	WHB	4	COLD	0.20						
M	KITCHEN	POU 015	4	HOT	0.15	M					
M	STAFF W/C	POU 003	4A	HOT	0.03	M					
Y	STAFF W/C	WHB	4A	HOT	0.04						
Y	STAFF W/C	WHB	4A	COLD	0.04						
Y	STAFF W/C	WHB	4B	HOT	0.06						
Y	STAFF W/C	WHB	4B	COLD	0.06						
Y	MEDICAL ROOM	WHB	7	HOT	0.23						
Y	MEDICAL ROOM	WHB	7	COLD	0.23						
M	MEDICAL ROOM	POU		MIXED	0.00	M					
M	STOREROOM	POU 024	16	HOT	0.24	M					
M	CLEANERS CUPBOARD	SENTINEL	17	HOT	0.36	M					
M	CLEANERS CUPBOARD	SENTINEL	17	COLD	0.36	M					
Y	BOYS W/C	WHB	17	HOT	0.28						
Y	BOYS W/C	WHB	17	COLD	0.28						
Y	BOYS W/C	WHB	17	HOT	0.30						
Y	BOYS W/C	WHB	17	COLD	0.30						
Y	BOYS W/C	WHB	17	HOT	0.34						
Y	BOYS W/C	WHB	17	COLD	0.34						
M	BOYS W/C (R)	TMV 027	17	MIXED	0.27	M					
M	BOYS W/C (M)	TMV 029	17	MIXED	0.29	M					
M	BOYS W/C (L)	TMV 033	17	MIXED	0.33	M					
Y	DISABLED W/C	WHB038	17A	HOT	0.38						
Y	DISABLED W/C	WHB 038	17A	COLD	0.38						
Y	GIRLS W/C	WHB 042	19A	HOT	0.42						
Y	GIRLS W/C	WHB 042	19A	COLD	0.42						
Y	GIRLS W/C	WHB 044	19A	HOT	0.44						
Y	GIRLS W/C	WHB 044	19A	COLD	0.44						
M	GIRLS W/C	POU 040	19B	HOT	0.40	M					
M	GIRLS W/C	TMV 041	19B	MIXED	0.41	M					
M	GIRLS W/C	TMV 043	19B	MIXED	0.43	M					
M	CLASSROOM	SENTINEL	21	HOT	0.47	M					
M	CLASSROOM	SENTINEL	21	COLD	0.47	M					
M	BOYS W/C	TMV 049	22A	MIXED	0.49	M					
M	BOYS W/C	TMV 051	22A	MIXED	0.51	M					
M	BOYS W/C	POU 048	23	HOT	0.48	M					
Y	BOYS W/C	WHB 050	23	HOT	0.50						
Y	BOYS W/C	WHB 050	23	COLD	0.50						
Y	BOYS W/C	WHB 052	23	HOT	0.52						
Y	BOYS W/C	WHB 052	23	COLD	0.52						
M	STORE ROOM	POU 056	27	HOT	0.56	M					
M	GIRLS W/C	TMV 057	27A	MIXED	0.57	M					
M	GIRLS W/C	TMV 059	27A	MIXED	0.59	M					
M	GIRLS W/C	TMV 061	27A	MIXED	0.61	M					
M	GIRLS W/C	TMV 063	27A	MIXED	0.63	M					
Y	GIRLS W/C	WHB 058	27A	HOT	0.58						
Y	GIRLS W/C	WHB 058	27A	COLD	0.58						
Y	GIRLS W/C	WHB 060	27A	HOT	0.60						
Y	GIRLS W/C	WHB 060	27A	COLD	0.60						
Y	GIRLS W/C	WHB 062	27A	HOT	0.62						
Y	GIRLS W/C	WHB 062	27A	COLD	0.62						
Y	GIRLS W/C	WHB 064	27A	HOT	0.64						

h. Legionella Flushing record form

NO	WHAT	LOCATION												
			JAN	FEB	MAR	APRIL	MAY	JUNE	JULY	AUG	SEPT	OCT	NOV	
4A	WHB	STAFF W/C												
4A	W/C	STAFF W/C												
4B	WHB	STAFF W/C												
4B	W/C	STAFF W/C												
4	SINK	KITCHEN												
4	SINK	KITCHEN												
4	SINK	KITCHEN												
7	SINK	1ST AID												
17	W/C X4	BOYS W/C												
17	WHB X4	BOYS W/C												
17	FOUNTAIN	BOYS W/C												
17a	W/C	DISABLED W/C												
17a	WHB	DISABLED W/C												
19b	W/C X3	GIRLS W/C												
19b	WHB X3	GIRLS W/C												
19b	FOUNTAIN	GIRLS W/C												
21	SINK	CLASSROOM												
22a	W/C	BOYS W/C												
22a	WHB X3	BOYS W/C												
22a	FOUNTAIN	BOYS W/C												
27a	W/C X7	GIRLS W/C												
27a	WHB X7	GIRLS W/C												
27a	FOUNTAIN	GIRLS W/C												
31a	W/C	DISABLED W/C												
31a	WHB	DISABLED W/C												
31b	W/C	STAFF W/C												
31b	WHB	STAFF W/C												
30	S X2	STAFF ROOM												
30a	W/C X2	STAFF W/C												
30a	WHB X3	STAFF W/C												
32	SINKS 2	ART ROOM												
38	W/C 2	PORTACABIN												
38	WHB X2	PORTACABIN												

39	W/C X2	PORTACABIN											
39	WHB X2	PORTACABIN											
A	HOSE	BY POND											
B	HOSE	SQUARE											
C	HOSE	STAFF AREA											
D	HOSE	OUTSIDE 21											

i. Legionella Controls

j. Risk Register

See the risk assessment register

k. Risk Assessment template

ASSESSING OUR RISKS –GENERAL RISK ASSESSMENT FORM				Risk Assmt. Ref: /000					
Site/Department:				Probability/ Severity	Minor injury	Lost time/ Ill Health	Major / >3 days	Perm. Disability	Fatal/ Site Loss
Task/Activity/Area:				Highly Unlikely	1	2	3	4	5
Notes: New Building (Including details of previous accidents/incidents)				Unlikely	2	4	6	8	10
RA Team: (Mgr, Supervisor, EHS Adviser, Safety Rep, Employee, minimum is 2 people)		Date of RA:	Review Date:	Possible	3	6	9	12	15
People at risk: Staff & Visitors (eg, visitors, contractors, hauliers, members of the public, operators, engineers, other employees etc)				Probable	4	8	12	16	20
Dept Manager (Print Name):		Signature:		Certain	5	10	15	20	25

Ref No. or Task-Step	Hazards identified or clear Injury causes, highlighting risks (Injury focused - see checklist)	Score - No controls	Controls/Procedures/Key Behaviours (existing controls, information, training etc)	Score - Post Controls	Further action required	Action Priority (H/M/L)

HAZARDS LIST (Potential for Injury)

Applies

POSSIBLE CONTROLS

Applies

Slips, Trips & Low falls (e.g. from wet/contaminated floors, steps, stairs, spillage risk etc)		Prohibition or Elimination - Stop doing the job
Struck by a falling object (lifted materials, lifting operations, overhead working, crane/tackle/beam failures etc)		Substitute with another method
Exposure to Hazardous Substances (Chemicals, oils etc, skin/absorption, eyes, respiratory, ingestion, CIP)		Isolate job (eg. enclose process) interlocking, fixed guarding etc or 'lock off & tag'
Exposure to biological agents or biological hazards (bacterial, rodent, viral, legionella)		Procedures - Safety, quality, production, Safe System of Work (approved), Work Instructions
Ergonomic/Posture Hazards (e.g. repetitive actions, over exertion/effort, awkward positions)		Maintenance and Statutory Checks (inc Planned Maintenance (PM) and PM inspections or tests)
Manual Handling Risks - lifting, carrying, pushing, pulling + (back strains, pulled muscles etc)		Inspections and/or housekeeping
Exposure to Gases, fumes (exhaust, solvent etc), dust, asbestos, ammonia		Training, Competent Persons, Authorised Controls, Permits or Licensing, schedules
Noise/Vibration exposure (over 80dBA, 85dBA, 90dBA, nuisance)		Warning Notices/signs, Physical Restrictions (note-may be portable)
Eye Injuries (e.g. foreign bodies, dust etc) and Display Screen Equipment / Visual Display Unit risks		Audible/Visual Warnings
Radiation Exposure (substances or ionising, light - Infra Red, Ultra Violet, Laser)		Safety Equipment (ie Mirrors, RCDs, guarding, emergency stops, barriers, handrails, ramps)
Electric Shock (or flash burns, static)		Reduced Time Exposure (Job rotation etc)
Cuts & Hand tool / power tool injuries and friction injuries (inc glass & paper cuts) and bruises etc		Measurement Sensors/Alarms (inc Gas detection checks)
Machinery Entrapment, crush injuries, entanglement (eg. Workshop machines, plant, mechanical hazards)		Ventilation (forced or general or Local Exhaust Ventilation (LEV)), good lighting, Environmental Controls
Fire, Highly Flammable Liquids, Pressurised gases, Explosion (inc Pressure explosions, boilers, hotwork, gases)		Specialist Surveys (ie noise, dust, vibration, thermographic etc)
Transport Risks (FLT/Pedestrian, FLT/FLT, Veh/FLT, Veh/Veh, Veh/pedestrian, trailers, mobile plant)		Manual Handling or Lifting Equipment provided
Vehicle Manouvers (including Reversing and loading)		Emergency Procedures (for foreseeable emergency situations)
Pressurised Systems, boilers, steam systems, pneumatics, hydraulics etc		Specific Safe System of Work (eg second operator, approval committees)
Burns/Scalds (hot or cold, or flames)		Suitable PPE (Shoes, Gloves, Hi-vis clothing, goggles/visors, masks, Breathing Apparatus, earplugs, hard hats etc)
Falls from Height (fragile roofs/work/holes, ladders, zip-up, scaffolding, racking, restricted access, cherry pickers)		*** Anything else that is helpful and could reduce the chance of injury
Asphyxiation (Confined spaces, excavations, drowning, gas suppression systems etc)		
Loneworking, restricted communications, Personal Protective Equipment (PPE) adding to risks (not fit for purpose, restricted vision etc)	tick	OTHER RISK ASSESSMENTS OR SPECIALIST SURVEYS REQUIRED;
Violence / aggression / assault		Control of Substances Hazardous to Health (inc LEV) Hazardous Substances
Striking against objects, Head Bangs, Body Bumps		Manual Handling
Structural collapse, exposed excavations etc, Contact with underground services (water, gas, electrics)		Display Screen Equipment
Temperature exposure (variations from normal, inc high/low temps, ventilation/humidity, heat stress/exhaustion)		Confined Spaces
		Working at Height
PEOPLE		Noise / Vibration
People risk groups - Young persons <18 or pregnant / nursing mothers / public / visitors		Work Equipment / Machinery - Provision and Use of Work Equipment
People risk groups - Loneworkers, night workers (Working Time Directive), customers, disabled workers		Young Persons
People risk groups - delivery drivers, contractors, maintenance staff, agency		Pregnant Women
*** Anything else that is foreseeable and could cause significant injury, consider emergency or abnormal activities in addition to start up, normal running and shutdown		Lifting Operations and Lifting Equipment
NOTE: In addition Business Unit Managers may need to check local requirements and modify stds to suit these.		Fire

I List of school key holders

Name	Role
Mike Bond	Site manager
Robert Jones	Headteacher
Samantha Cantini	Deputy Headteacher
Mary Fountain	Finance Manager

New Staff Health & Safety Induction Checklist

INDUCTION TASKS AND TRAINING REQUIREMENTS	DATE OF COMPLETION	COMMENTS/ FURTHER ACTIONS
<p>Tour/walk around of work area</p> <ul style="list-style-type: none"> • Show work areas • Show where amenities/toilets situated • Arrangements for eating meals and taking breaks • Changing/locker facilities • Hazardous areas 		
<p>Health & safety policy and safety procedures</p> <ul style="list-style-type: none"> • Read copy of H&S policy • Discuss areas within H&S policy • Show H&S notice board • Show all other appropriate policies • Show all other appropriate procedures 		
<p>Child protection policy</p> <ul style="list-style-type: none"> • Read copy of child protection policy • Discuss areas within child protection policy 		
<p>Physical intervention policy</p> <ul style="list-style-type: none"> • Read copy of physical intervention policy • Discuss areas within physical intervention policy 		
<p>Action on discovering a fire/bomb warning</p> <ul style="list-style-type: none"> • Read fire evacuation procedure • Show fire exits/assembly point/fire call points • Fire warning system explained • Location of fire equipment indicated • Introduce to Fire Safety Co-ordinator • Introduce to fire marshal (where necessary) • Complete PEEP if required • Read bomb warning • Bomb warning system explained 		
INDUCTION TASKS AND TRAINING REQUIREMENTS	DATE OF COMPLETION	COMMENTS/ FURTHER ACTIONS
<p>Security arrangements</p> <ul style="list-style-type: none"> • Open up/lock up procedures • Access identification/codes • Lone working procedures • Key holders list 		

<ul style="list-style-type: none"> • Visitor procedures 		
First aid provision <ul style="list-style-type: none"> • Local first aid procedures explained • Read first aid policy • Introduction to first aiders • Location of first aid box/room indicated • Local procedures where health care plan required 		
Accident/incident reporting procedures <ul style="list-style-type: none"> • Accident reporting procedure for staff • Accident reporting procedure for children • Introduce to accident investigator • Violent incident reporting procedure 		
Other training course requirements <ul style="list-style-type: none"> • Hazardous substances • Fire safety induction • Moving and handling 		
Display screen equipment (for DSE users only) <ul style="list-style-type: none"> • Complete basic DSE training induction • Complete Workstation Assessment DSE Checklist 		
Additional H&S training requirements <ul style="list-style-type: none"> • Refer to training needs analysis • Consider the role and tasks of new staff member 		

Following completion of this induction checklist, ensure that it is signed and filed as evidence of completion. Any follow- up action should be planned in bring-up diary and actioned as necessary.

Name of member of staff	Signature of member of staff	Date

Name of manager/headteacher	Signature of manager/headteacher	Date

I. Medicine Consent Form

m. Water Schematic Drawing.

n. Violent Incident Report Form

o. Daily, weekly, monthly and 3 monthly checks

actioned by the site manager

This list is not intended to be exhaustive.

Daily tasks

- Unlock & lock the school (including setting the alarm where applicable)
- Ensure heating and lights are on where necessary and switched off at the end of the day
- Check all windows and doors are closed at the end of the day
- Ensure all fire escapes are clear and unlocked
- Inspect the school grounds and clear grounds of litter
- Deal with any unpredicted hazards e.g. broken glass, fire or trip hazards, animal fouling etc.
- Disinfect all toilet fixtures (toilets, sinks, showers) and drinking fountains
- Vacuum and maintain all rooms, halls, staircases, corridors and cloakrooms
- Ensure doors, furniture, windowsills and ledges are wet dusted as necessary and tables wiped
- Check and refill all paper dispensers, toilet rolls and soap dispensers
- Minor maintenance tasks
- Empty bins
- Check boiler houses, ensure heating on and working correctly;
- Check temperature in all parts of school;
- Check fire panel daily, log any faults, sign, action;
- Check throughout day job worksheet for any Health & Safety issues.

Weekly tasks

- Inspect the roof and remove any play equipment or litter
- Dust shelves, desks and fixtures as necessary
- Check paper and cleaning supply inventory and order as required in timely fashion
- Inspect playground equipment and outside areas
- Test lighting systems and replace light bulbs and florescent tubes where necessary
- Test the fire alarm
- Put the bins out for collection
- Meet with the Headteacher to programme following week
- Flush through any points in school (taps, showers, toilets not regularly used) enter/sign into log.
- Test break glass points in school on a rotational basis, this is recorded and logged. This is carried out with the help of a member of staff.
- Check all fire extinguishers, fire blankets, fire doors and automatic closing doors in school. Check gauge and condition of equipment: log and sign.

Monthly tasks

- Audit and log any major maintenance tasks

- Read electricity, gas and water meters and give to the Headteacher or SBM
- Meet with the Headteacher to discuss work programme and check all logs and records
- Carry out monthly Legionella water temperature checks (log and sign).
- Carry out monthly 15-minute test of emergency lights (log and sign).
- Visual check of outside play area (wooden areas) (log and date).

Termly/seasonal tasks

- Check and maintain the site manager's equipment and storage areas and order any items needed for health and safety e.g. grit, hazard tape etc.
- Carry out full health and safety check
- Arrange and monitor fire drills
- Monitor that all health and safety checks (e.g. fire alarm & extinguisher) have been carried out
- Advise the Headteacher when the annual safety test on electrical, PE and fire equipment is due
- Clean the windows (or arrange for them to be cleaned)
- Pruning trees
- Clearing gutters & drains, including the rainwater hoppers: Log and sign
- Cleaning carpets